

SoleMon - *Rapido* trawl surveys in the Northern Adriatic Sea

SoleMon Handbook

Version 4



JULY 2019

Preamble

The SoleMon (Solea Monitoring) project was set up by the Italian Ministry for Agriculture and Forestry (D.G. Fisheries and Aquaculture) in 2005, in the framework of the 6th triennial plan, to monitor marine fishery and aquaculture in marine and brackish waters (Theme C – C6) and was funded by the Ministry until 2006. The project enlisted the major marine research institutions operating along the coasts of the Adriatic: on the western side the Ancona branch of CNR-ISMAR (now CNR-IRBIM, Institute for Biological Resources and Marine Biotechnologies) and the Chioggia branch of the Italian National Institute for Environmental Protection and Research (ISPRA, *Istituto Superiore per la Protezione e la Ricerca Ambientale*, formerly ICRAM) and on the eastern side the Institute of Oceanography and Fishery (IOF) in Split (Croatia) and the Fisheries Research Institute of Slovenia (FRIS) in Ljubljana.

Cooperation among the institutes was facilitated by an existing international network set up within the FAO AdriaMed regional project. The SoleMon project involved performing trawl surveys using a modified beam trawl (the *rapido* trawl) to collect landings, catch and effort data of the commercial fleets from both sides of the Adriatic. Since 2007, AdriaMed has been covering the travelling expenses of the Croatian and Slovenian scientists. The continuation of the data series to the present time has largely been supported by CNR-ISMAR Ancona with funding coming mostly from the private sector. Since 2017, when the survey was endorsed by the Italian Fishery Data Collection Programme (*Programma Nazionale Raccolta Dati Alieutici*), it is no longer a stand-alone project but an integral part of the programme.

A handbook describing the survey protocol and detailing the specifications for the main tasks performed in its framework was prepared in the early years of the project (Fabi et al., 2009). Because several improvements have accrued since then, a new version was felt to be needed. The SoleMon coordination committee has ensured that the changes described in the present version of the handbook do not affect the consistency of the series.

Coordination of the SoleMon programme

Coordination

The SoleMon programme is currently coordinated at the international level by Giuseppe Scarcella of CNR-IRBIM; notably, since 2009 it is also coordinated in the framework of the ICES Working Group on Beam Trawl Survey (WGBEAM).

The current composition of the SoleMon survey group is reported in Table 1; the letter N indicates the members of the Steering Committee.

Table 1- SoleMon survey group and Steering Committee.

Country	Scientist name	Affiliation	Address/Telephone	Email address
Italy	Giuseppe Scarcella N – Coordinator	Institute for Biological Resources and Marine Biotechnologies - National Research Council, CNR-IRBIM, Ancona	L.go Fiera della Pesca SNC 60125 – Ancona, Italy Tel. +39 071 207 8849 Fax +39 071 55 313	giuseppe.scarcella@cnr.it
Italy	Piero Polidori	Institute for Biological Resources and Marine Biotechnologies - National Research Council, CNR-IRBIM, Ancona	L.go Fiera della Pesca SNC 60125 – Ancona, Italy Tel. +39 071 207 8849 Fax +39 071 55 313	piero.polidori@cnr.it
Italy	Laura Sabatini	Institute for Biological Resources and Marine Biotechnologies - National Research Council, CNR-IRBIM, Ancona	L.go Fiera della Pesca SNC 60125 – Ancona, Italy Tel. +39 071 207 8849 Fax +39 071 55 313	laura.sabatini@irbim.cnr.it
Italy	Pierluigi Strafella	Institute for Biological Resources and Marine Biotechnologies - National Research Council, CNR-IRBIM, Ancona	L.go Fiera della Pesca SNC 60125 – Ancona, Italy Tel. +39 071 207 8849 Fax +39 071 55 313	pierluigi.strafella@cnr.it
Italy	Otello Giovanardi N	Italian National Institute for Environmental Protection and Research, ISPRA, Chioggia	Loc. Brondolo, c/o Mercato Orticolo - 30015 Chioggia, Italy Tel. +39 041 554 3933 Fax +39 041 554 7897	otello.giovanardi@isprambiente.it
Italy	Saša Raicevich	Italian National Institute for Environmental Protection and Research, ISPRA, Chioggia	Loc. Brondolo, c/o Mercato Orticolo - 30015 Chioggia, Italy Tel. +39 041 554 3933 Fax +39 041554 7897	sasa.raicevich@isprambiente.it
Italy	Tomaso Fortibuoni	Italian National Institute for	Via Ca' Fornacetta 9	tomaso.fortibuoni@isprambiente.it

Country	Scientist name	Affiliation	Address/Telephone	Email address
		Environmental Protection and Research, ISPRA, Ozzano Emilia	I-40064 OZZANO EMILIA, Bologna, Italy Tel. +39 051 651526	
Slovenia	Bojan Marceta N	Fisheries Research Institute of Slovenia (FRIS)	Sp Gameljne 1211 Ljubljana-Smartno Tel. (0)1 244 3400 Fax (0) 1 244 3405	Bojan.Marceta@zzrs.si
Croatia	Nedo Vrogc N	Institute of Oceanography and Fisheries (IOF), Split	Šetalište I. Meštrovića 63,21000 Split; Tel.+(385) 21 408 000 Fax +(385) 21 358 650	vrgoc@izor.hr
Croatia	Marija Despalatovic	IOR - Institute of Oceanography and Fisheries, Split	Šetalište I. Meštrovića 63,21000 Split; Tel. +(385) 21 408 000 Fax +(385) 21 358 650	mare@izor.hr

Contents

1.1 RAPIDO TRAWL	9
1.2 RIGGING	10
1.3 WARP DIAMETER AND LENGTH	10
1.4 COMPLEMENTARY EQUIPMENT	11
[2] SAMPLING METHODOLOGY	12
2.1 VESSEL CHARACTERISTICS	12
2.2 SAMPLING: TIME OF THE YEAR	12
2.3 SAMPLING STRATEGY AND HAUL POSITION	12
2.4 GEAR OPERATION	13
2.4.1 Sampling: time of day	13
2.4.2 Haul duration	13
2.4.3 Haul start and end	13
2.4.4 Haul depth	13
2.4.5 Vessel speed	13
2.4.6 Gear contact with the bottom	14
[3] CATCH PROCESSING	15
3.1 CATCH SORTING	15
3.2 BIOLOGICAL PARAMETERS	15
3.2.1 Measurement units	16
3.2.2 Sex and maturity	16
3.2.3 Otoliths	17
3.3 OTHER PARAMETERS	17
[4] QUALITY ASSURANCE	17
[5] DATA INPUT, STORAGE AND USE POLICY	18
[6] REFERENCES	20
[6] ANNEXES	21

INTRODUCTION

This is the fourth version of the SoleMon Handbook. The manual was originally drawn up in the context of an international project, set up by the Italian Ministry for Agriculture and Forestry (D.G. Fisheries and Aquaculture) in 2005 in the framework of the 6th triennial plan, to monitor marine fishery and aquaculture in marine and brackish waters (Theme C – C6), and was funded by the Ministry until 2006. The project enlisted the major marine research institutions operating along the coasts of the Adriatic: on the western side the Ancona branch of CNR-ISMAR (now CNR-IRBIM, Institute for Biological Resources and Marine Biotechnologies) and the Chioggia branch of the Italian National Institute for Environmental Protection and Research (ISPRA *Istituto Superiore per la Protezione e la Ricerca Ambientale*, formerly ICRAM) and on the eastern side the Institute of Oceanography and Fishery (IOF) in Split (Croatia) and the Fisheries Research Institute of Slovenia (FRIS) in Ljubljana. The present handbook provides the reference framework for the surveys conducted since 2012 to monitor the continental shelves of the Northern Adriatic Sea (FAO-GFCM Geographical Sub-Area [GSA] 17) up to a depth of 100 m (Fig.1). In 2016 and 2017 the survey area was extended to Croatian waters with seven additional stations, which are not shown in Figure 1. The SoleMon meeting held in Ancona on 16-20 May 2011 decided to expand the survey database by collecting additional biological parameters such as the age of commercially important flatfish species, additional of target species, and additional items such as litter and stomach contents, thus providing useful information also for the Marine Strategy Framework Directive (MSFD) project (FAO AdriaMed, 2015).

The handbook describes the sampling gear characteristics, the sampling methodology, and sample processing and provides the specifications for data storage files and exchange (ATrIS database and TruST database).

This version of the manual closely reflects the evolution of the SoleMon surveys. However, the continuing progress made to meet new objectives and the end of the trial stage of a number of changes, adopted in version 3, entail that additional modifications and improvements will be introduced in the near future.

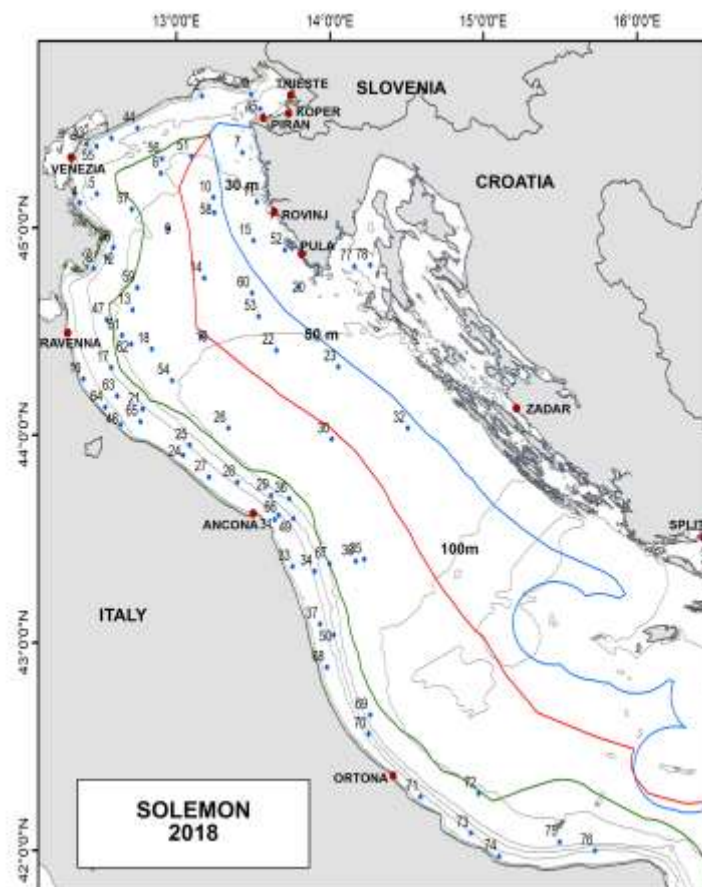

Figure 1 – Haul positions in GSA 17 (Italy and Slovenia) from 2007 to the present (Image courtesy of Carmen Ferrà Vega).

OBJECTIVES

The SoleMon surveys collect distribution, relative abundance and biological data on commercial marine species in GSA 17 for use in stock assessment and fishery management. The primary target species is common sole (*Solea solea*); further target species include spottail mantis squillid (*Squilla mantis*), common cuttlefish (*Sepia officinalis*), great Mediterranean scallop (*Pecten jacobaeus*), queen scallop (*Aequipecten opercularis*), turbot (*Scophthalmus maximus*), brill (*Scophthalmus rhombus*), European hake (*Merluccius merluccius*), red mullet (*Mullus barbatus*), skates (Rajidae) and the caramote prawn (*Penaeus kerathurus*).

Since 2007, the SoleMon surveys have been moving towards an increasingly ecosystem integrated approach, and further tasks (e.g. seafloor litter and megazoobenthos monitoring) have been added to the original goals, which are still priority objectives. Although adding further tasks to an existing survey can only occasionally produce an ‘ideal survey’ of the full ecosystem or encompass all MSFD descriptors, a newly created survey can set accuracy constraints for some of the data collected, based on prioritization.

The new tasks, notably those involving evaluation of the MSFD indicators, will be incorporated into the SoleMon survey protocol according to the roadmap agreed by the ICES Working Group on Integrating Surveys for the Ecosystem Approach (ICES, 2012).

Since 2009, the SoleMon surveys have also been coordinated in the framework of the ICES WGBEAM and included in the WGBEAM Manual for Offshore Beam Trawl Surveys. The researchers involved in the SoleMon surveys participate in the ICES WGBEAM annual meeting, and common sole data have been uploaded in the DATRAS database since 2016 (<https://ices.dk/marine-data/data-portals/Pages/DATRAS.aspx>).

Additional tasks should be undertaken only when the objective for the data collection is clearly defined, since the most appropriate collection method may vary from one objective to another. Moreover, processing of some samples is resource-intensive: if expertise in a given field of interest is limited, it may be outsourced through collaborations with other institutes/universities, since samples are not required to be processed by the institute that has collected them.

[1] SAMPLING GEAR SPECIFICATIONS

1.1 *Rapido* trawl

A modified beam trawl with a rigid mouth, called *rapido* trawl by Italian fishermen, has been employed in the SoleMon surveys since 2005 (Fig.2). The frame is rigged with 46 iron teeth along the lower leading edge. Joined to the iron frame are 4 skids; a reinforced rubber diamond-mesh net in the lower part protects the polyamide net bag (width, 3.59 m; height, 0.25; weight, 225 kg; 4 120-mm wide skids). A wooden plank fitted to the front of the iron frame at around 35° angle acts as a spoiler to keep the skids and the teeth in contact with the seafloor (Figure 2). A detailed drawing is reported in Annex I. The gear design ensures efficient use on several seafloor types and requires a towing power of at least 400 HP. Mesh sizes are reported as bar length in Figure 3. The mesh numbers for height correspond to well-finished and joined netting sections; the joining mesh is also shown. The codend is 2.7 m long.

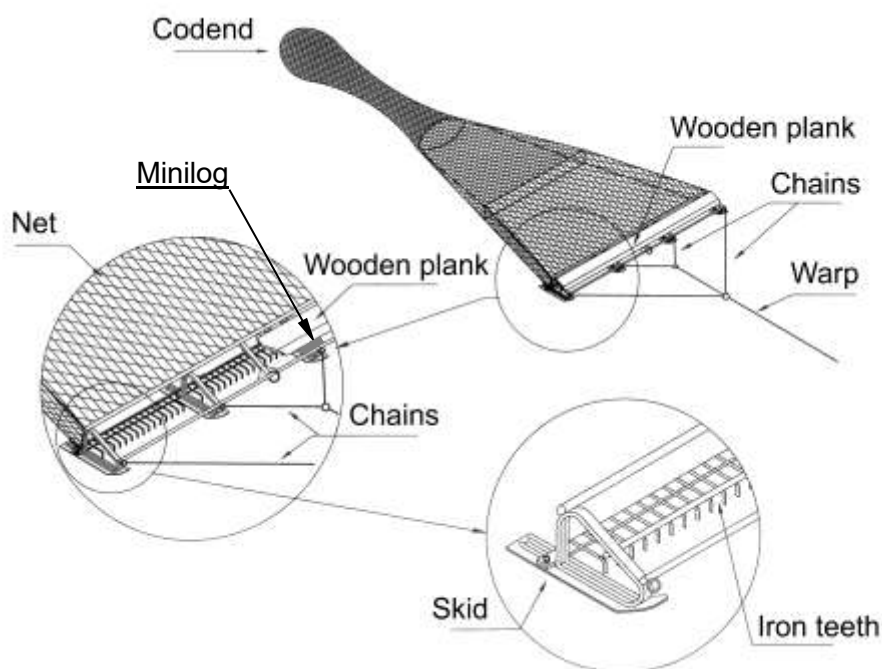

Figure 2 - *Rapido* trawl.

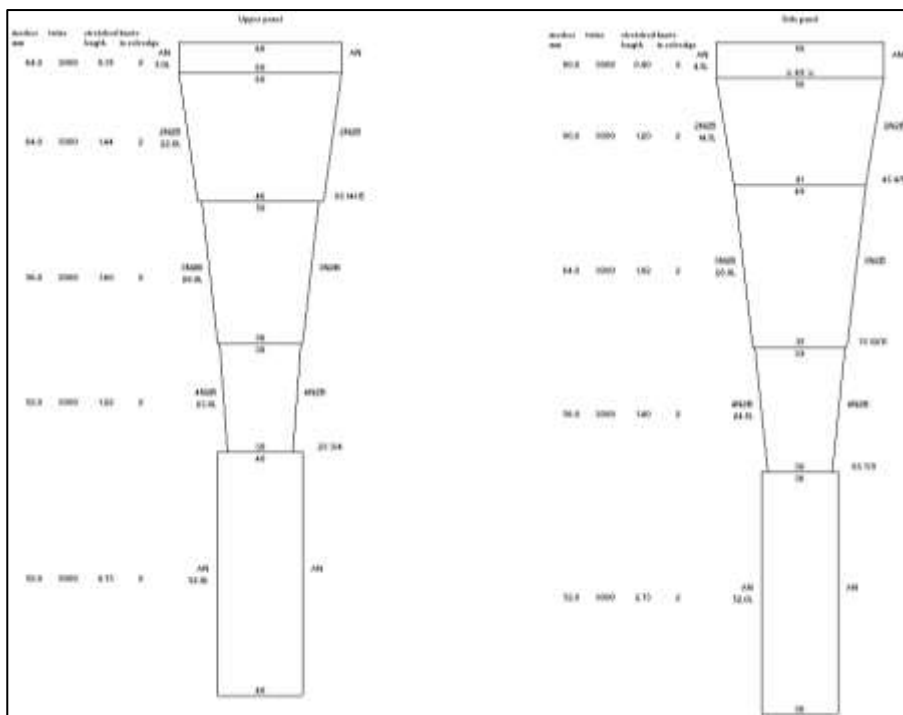

Figure 3 – Rapido trawl net.

1.2 Rigging

The vessel tows two gears simultaneously, “RAPIDO A” (right) and “RAPIDO D” (left) (Figure 4).

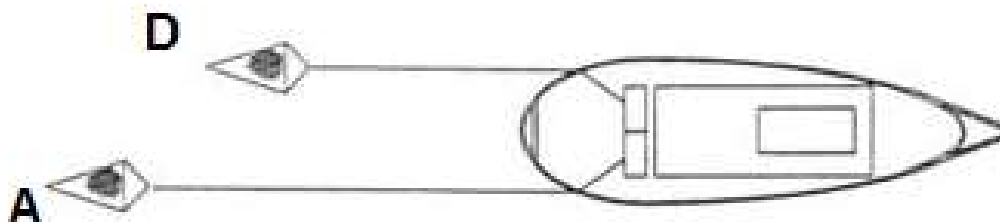

Figure 4 – Gear arrangement during the haul.

1.3 Warp diameter and length

Given the gear and rigging characteristics of the *rapido* trawl, the warps should be 14-16 mm in diameter. Warp length is a function of depth; the recommended relationship is shown in Figure 5. Although adjustments are acceptable in exceptional circumstances, the depth/warp length ratio should be respected wherever possible. To avoid interference between the gears during towing, the warp of RAPIDO A is 15 m longer than the warp of RAPIDO D (Figure 5).

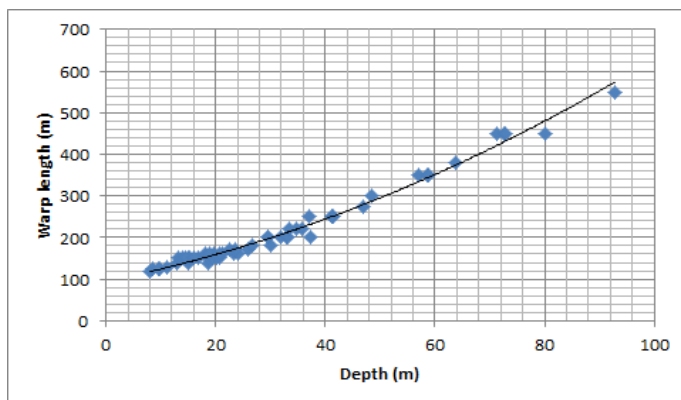

Figure 5 - Relationship between fishing depth and warp length for the *rapido* trawl.

1.4 Complementary equipment

The gears are provided with DST logic temperature and depth loggers, which record data at set frequencies (i.e. 1 min). The fixed width of the gear multiplied by vessel speed, allows estimating the swept area, i.e. the area trawled by each gear.

[2] SAMPLING METHODOLOGY

2.1 Vessel characteristics

Since 2007, after intercalibration with the commercial vessels used in the earlier surveys, all SoleMon surveys have been performed by research vessel “G. Dallaporta”. Its technical characteristics are summarized below:

- Length (m): 35.3
- Tonnage (TJB): 285
- Year of construction: 2000
- Material: Steel
- Power (kW): 809
- Warp diameter (mm): 14-16
- Warp length (m): 2500

To minimize year to year variation due to the vessel effect, the same vessel and, where possible, the same crew have been involved in the surveys.

2.2 Sampling: time of the year

The SoleMon surveys are carried out from October to December, especially in November.

2.3 Sampling strategy and haul position

The hauls are planned according to a depth-stratified sampling scheme with random allocation of the positions of sampling stations within each stratum. The sampling effort is determined on the basis of a number of technical constraints (e.g. vessel availability) and since 2008 it has been involving 67 stations, 66 in Italian and international waters and 1 in Slovenian waters. Seven extra stations inside Croatian waters are carried every year. Accuracy can be maximized (narrower confidence limits) by concentrating sampling in high-abundance areas or strata. Stratified sampling requires an initial systematic survey, to identify the distribution of the stocks of the target species in the strata. For this reason, two systematic “pre-surveys” were carried out in spring and autumn 2005. Stations from the Italian to the Croatian coast were set at 7 nm intervals along 11 transects, totalling 68 stations in spring and 62 in autumn; the reduction was due to the exclusion of 6 stations set at a depth exceeding 100 m, which may be considered as the lower limit of the distribution of several target species.

A standard method based on the Neyman equation (Neyman, 1934) was applied to define the strata, establish the number of stations allocated to each of them, and maximize the accuracy of the abundance estimate of a pool of target species. The abundance and variance of the data collected in the systematic pre-surveys were used to find a mathematical solution to the allocation problem, which needed to be solved numerically. Application of an iterative procedure based on computer scripts implemented in R provided the exact solutions and suggested the improvements that could be obtained by including different strata.

The allocation exercise led the 67 stations to be distributed over GSA 17 (Figure 1), with a random depth-stratified design (0-30 m, 39 stations; 30-50 m, 17 stations; 50-100 m, 11

stations), to maximize coverage of the area. The number of stations per stratum is proportional to its surface area (Tab.2.3.1). Since autumn 2007, except in case of severe problems (e.g. damage seen in previous years), the hauls involved consistently the same stations.

Table 2.3.1 – Stratum characteristics.

GSA	Country	Stratum	Depth (m)	Surface(km ²)	Area
17	Italy	STR1_17	5-30	11361	Northern-Central Adriatic Sea
17	Italy - Croatia	STR2_17	30-50	8410	“
17	Italy - Croatia	STR3_17	50-100	22466	“
17	Slovenia	STR1_SLO	5-30	151	Northern Adriatic Sea
17	Croatia	HRV			Northern Adriatic Sea*

* = carried out only in 2006, 2016 and 2017

2.4 Gear operation

2.4.1 Sampling: time of day

The hauls are performed in daylight, which is the time between 30 minutes after sunrise to 30 minutes before sunset.

2.4.2 Haul duration

A station consists of a daytime haul towing the two gears. Haul duration is 30 minutes, which start when the gear settles on the bottom and end when hauling begins. A shorter haul duration (though never shorter than 10 minutes) is allowed in some circumstances (e.g. rough fishing ground); in such cases, the haul is repeated and the catches are pooled together.

Speed and distance are monitored and recorded by the onboard instruments.

2.4.3 Haul start and end

The interval between the start and end of the haul is calculated using the depth profile provided by the DST logic temperature and depth loggers and the time frequency of the data, which are recorded at 30-second intervals.

2.4.4 Haul depth

The hauls are commonly made at a constant depth; variations should not exceed 5% relative to the initial depth. Any discrepancies should be recorded.

2.4.5 Vessel speed

Vessel speed during shooting is relatively high (6-7 knots). When the gears touch the bottom speed is reduced to as little as 4 knots, then it is gradually increased up to 5.5 knots. These specifications should be accurately followed, except in cases where adjustments – which

should be as small as possible – are absolutely necessary.

2.4.6 Gear contact with the bottom

The gears should trail on the seafloor throughout the haul. This should be checked regularly through the DST logic temperature and depth loggers, by monitoring of the skids or by examination of the benthic organisms in the catches after the haul.

[3] CATCH PROCESSING

3.1 Catch sorting

The catches of the “RAPIDO A” and “RAPIDO D” gears should be analysed separately. The whole catch of each gear should be weighed and sorted. The total number and weight should be evaluated for each finfish, ray, shark, cephalopod and commercially important shellfish and crustaceans species (Tab.3.2.1).

The entire fraction or a subsample of epibenthos/benthos, debris (shells, wood, etc.) and litter (see the “Quality assurance” section below) found in one of the trawls should be weighed and analysed fresh on board by recording the wet weight and the number of items for each category and by identifying taxa to the lowest possible taxonomic level.

The species and codes updated to 2019 are listed in annex III. The species list should continuously be revised based on the information available in the World Register of Marine Species (Horton et al., 2019).

3.2 Biological parameters

Species should be classified on the basis of biological characteristics and economic importance into “Faunistic categories” (Annex III). Each individual of category A (bony fishes and elasmobranchs), B (commercially important crustaceans) and C (cephalopods) species should be measured to the millimetre below, whereas those of category D (commercial shellfish) should be counted. Further biological parameters should be collected as reported in Table 3.2.1 For length measurements, subsampling by species is acceptable in case of extremely high numbers.

Table 3.2.1 – Target species and biological parameters.

Species	Length	Sex and maturity	Individual weight (g)	Otolith	Tissue for genetic analysis	Stomach	Entire specimen
<i>Solea solea</i>	Yes	Yes	Yes	Yes	Yes*	Yes*	Yes*
<i>Solea aegyptiaca</i>	Yes	Yes	Yes	Yes	Yes*	Yes*	Yes*
<i>Platichthys flesus</i>	Yes	Yes	Yes	Yes			
<i>Scophthalmus maximus</i>	Yes	Yes	Yes	Yes			
<i>Scophthalmus rhombus</i>	Yes	Yes	Yes	Yes			
<i>Merluccius merluccius</i>	Yes	Yes	Yes				
<i>Mullus barbatus</i>	Yes	Yes	Yes				
<i>Raja asterias</i>	Yes	Yes	Yes				
<i>Raja clavata</i>	Yes	Yes	Yes				
<i>Parapenaeus longirostris</i>	Yes	Yes (only females)	Yes				
<i>Penaeus kerathurus</i>	Yes	Yes (only females)	Yes				
<i>Nephrops norvegicus</i>	Yes	Yes (only females)	Yes				
<i>Squilla mantis</i>	Yes	Yes (only females)	Yes				

Species	Length	Sex and maturity	Individual weight (g)	Otolith	Tissue for genetic analysis	Stomach	Entire specimen
<i>Sepia officinalis</i>	Yes	Yes	Yes				
<i>Pecten jacobaeus</i>	Yes		Yes				
<i>Aequipecten opercularis</i> / <i>Flexopecten glaber</i>	Yes		Yes				
OTHER ELASMOBRANCHS	Yes		Yes				
OTHER FISH AND COMMERCIAL SPECIES (CATEGORIES A, B and C)	Yes		TOTAL WEIGHT				
OTHER COMMERCIAL SHELLFISH (CATEGORY D)	TOTAL NUMBER		TOTAL WEIGHT				

* = to be analysed only if both Solea species are found in a haul

3.2.1 Measurement units

Fish (bony fishes and elasmobranchs) length should be measured with the tail extended, recording the longer dimension to the nearest millimetre below.

Crustaceans: length should be measured as cephalothoracic length to the nearest millimetre below.

Cephalopods: the length of the mantle should be measured to the nearest millimetre below.

For commercially important bivalves, shell length should be measured to the nearest millimetre below.

The standard measurements, illustrated by drawings, are reported in Annex IV.

3.2.2 Sex and maturity

Sex is recorded according to four categories: male, female, undetermined (impossible to establish by visual examination) and not determined (the individual was not examined). Sex data should be collected for the target species listed in Table 3.2.1.

Sexual maturity should be defined with reference to the identification keys reported in Annex V. A combined scale (modified from ICES, 2012c) should be used for common sole, since identifying the different stages by the MEDITS scale proved very difficult and often required using a microscope (Follesa et al., 2019). The MEDITS (2017) maturity scales should be used for other bony fishes, oviparous elasmobranchs, and cephalopods. The Froglija scale (1996) should be employed for *S. mantis*. A two-level classification has been adopted for *P. kerathurus* females, based on the presence/absence of the spermatophore, whereas *P. longirostris* females should be assigned to the categories immature/developing/maturing (considering stage 1, 2a, 2b and 2c together) and mature (stage 2d) based on the MEDITS (2017) crustacean maturity scale.

3.2.3 Otoliths

Since 2007 the information recorded during the SoleMon survey has been expanded to include further variables like the age of commercially important flatfish species and individual weight.

Otoliths should be collected from common sole, turbot, brill and European flounder. After their removal the individual should be weighed, and sex and maturity stage recorded. Common sole otolith sampling is stratified in three areas – stations south of Ancona; north of Ancona, and in international waters – to maximize the coverage of its spatial distribution and involves collecting 10 otoliths per cm class in each area. Sagittal otoliths should be extracted with steel tweezers, cleaned and stored dry in labelled polypropylene tubes.

In line with the “Handbook on fish age determination” (Carbonara and Follesa, 2019), hemisections through the core should be obtained in the laboratory from soles with a total length (TL) ≥ 28 cm and from those whose age is doubtful. One otolith (the same where possible) should be burned, embedded in epoxy resin and sections approximately 0.8-1 mm in thickness should be cut transversely through the core using a metallographic machine (e.g. a Remet Micromet).

3.3 Other parameters

Before beginning a station, a vertical cast with a CTD probe should be made to measure high-resolution temperature, salinity and turbidity (optional).

A Minilog depth-temperature unit (“StarOddi” - Garðabær, Iceland) secured to each gear records temperature, depth and salinity data throughout the tow.

Biometric data and tissue samples for genetic testing should be collected to distinguish *S. solea* from of *S. aegyptiaca* specimens in the Northern Adriatic. Genetic samples of common sole should also be collected for analysis with high-resolution markers. Comparison of their genetic traits with those of populations sampled in the adjacent GSA 18, which have already been genotyped, will provide evidence for or against separate stocks in the two GSAs

Finally, stomach, flesh and liver samples of some finfish species should be collected to analyse trophic level, diet and contaminants (e.g. lindane, TBT).

[4] QUALITY ASSURANCE

Gear: standard gear characteristics are employed to preserve a consistent gear setting and configuration. A check is performed before and after each cruise and a daily gear logbook is compiled at the end of each haul. If the gear has suffered damage it is replaced. New iron teeth are fitted for each haul.

Identification: current systematic keys are commonly used for onboard species identification. In 2011, a taxonomic identification workshop was organized for the personnel who take part in the surveys; a final list of species was drawn up and checked for synonyms and mistakes.

Since 2010, a further effort is being made to sort, count and weigh epibenthos/benthos species and debris items fresh onboard.

Subsampling of epibenthos/benthos species and debris is performed routinely. Since 2011 it has been regulated as follows:

- if the weight of epibenthos/benthos species and debris in one gear is ≤ 30 kg, they are all sorted directly without subsampling;
- if the weight of epibenthos/benthos species and debris in one gear is > 30 kg, a subsample ranging from 50% to 5% of the catch is taken and sorted directly as described in Table 4.1.

The epibenthos/benthos species and debris fractions measured in one, randomly selected *rapido* trawl are assumed to be identical to those found in the other gear. Their amount in the other gear is standardized on the basis of the overall catch weight by calculating the raising factor (R.F.) as follows:

$$\text{R.F.} = \frac{\text{Sum of the weight of epibenthos/benthos species and debris from Rapido A and D}}{\text{Weight of the sample of epibenthos/benthos species and debris}}$$

Table 4.1 – Subsampling of the epibenthos/benthos species and debris fraction.

Weight of the epibenthos/benthos species and debris fraction (kg)	Percentage to be sampled
≤ 30	100
$> 30 \geq 60$	50
$> 60 \geq 500$	20
$> 500 \geq 1500$	10
> 1500	5

Litter subsampling: data on marine litter have begun to be collected in 2009. In 2011 and 2012, all items found in each haul were picked manually from the hopper, weighed, counted, photographed but not sorted; as a result, this fraction was recorded as number of items and weight as a whole (code, ANTHDIS). From 2013 to the present, anything visible that is found in RAPIDO D is separated manually, photographed, classified according to ICES subcategories (ICES, 2012b), counted and weighed. The 46 subcategories employed in 2013-2016 became 52 in 2017 (other textiles; middle-size containers [of paint, oil, chemicals]; large metal objects; carpets & furnishings; food containers/wrappers; other fishing-related litter (pots, floats, etc.). This information is reported in annex II. Data for each subcategory are recorded in a separate reporting sheet (Annex II). To help comparison of the data collected in different surveys and countries, a conversion table of the codes used in the SoleMon masterlist and of those used in the IBTS (ICES, 2018), MEDITS (MEDITS working group, 2016) and TG-ML (Galgani et al., 2013) protocols is reported in annex II.

[5] DATA INPUT, STORAGE AND USE POLICY

Data are stored in the dedicated ATrIS database (Gramolini et al., 2005). The catches of each trawl are entered separately with an identification code that is composed of four digits: the first two indicate the number of the station; the third is the haul number (usually 1; it is 2 only in those cases where a haul lasted less than 10 minutes and was repeated); and the fourth

indicates the *rapido* trawl (A = 1, D = 4). After all the data have been entered, the catches of the two trawls are pooled together under the code SOLEMON 20XX_b.

The .mdb files – of which one contains the original data and the other reports the *Solea* spp. data corrected for selectivity – are stored in a common server.

The SoleMon dataset use policy states the conditions for data access and use. From 2005 to 2016 prospective data users (persons, organizations, groups) have been required to obtain the authorization of the responsible officials of IRBIM-CNR, ISPRA, IOF or FRIS before submitting an official request to the SoleMon Steering Committee. Since then, the application must be submitted to the relevant administration (e.g.: Italian Ministry of Agricultural, Food, Forestry and Tourism Policies – MIPAAFT).

Users are required to respect the restrictions placed on data use. The use of data, once granted, is limited to the publication or working group stated in the request.

The use of DATRAS data is managed by the ICES data policy (<https://ices.dk/marine-data/Documents/ICES-Data-policy.pdf>). The data cannot be redistributed, i.e. included in other data collections or publications, without the authorization of the SoleMon Steering Committee.

Since 2016, the common sole data are also annually uploaded and stored in the ICES DATRAS database, after a thorough quality check.

[6] REFERENCES

- AdriaMed, 2015. SoleMon survey in the Northern Adriatic Sea (GSA 17):outcomes and new perspectives Technical Documents No. XX - GCP/RER/000/ITA/TD-XX. Ancona (Italy), December 2011. 75 pp.
- Fabi G., Giovanardi O., Grati F., Raicevich S., Santojanni A., Scarcella G. 2009. Valutazione dello stock di *Solea solea* del medio e alto Adriatico e dell'incidenza di diverse attività di pesca. Relazione finale. Ministero per le Politiche Agricole e Forestali. Direzione generale della pesca e dell'acquacoltura. VI Piano Triennale della pesca marittima e acquacoltura in acque marine e salmastre (tematica c – c6). Programma di ricerca 6-a-74. 133 – XVII pp.
- Follesa, M.C., Carbonara, P., eds. 2019. Atlas of the maturity stages of Mediterranean fishery resources. Studies and Reviews n. 99. Rome, FAO. 268 pp.
- Galgani, F., Hanke, G., Werner, S., Oosterbaan, L., Nilsson, P., Fleet, D., Kinsey, S., Thompson, R.C., Van Franeker, J., Vlachogianni, T., Scoullou, M., Mira Veiga, J., Palatinus, A., Matiddi, M., Maes, T., Korpinen, S., Budziak, A., Leslie, H., Gago, J., Liebezeit, G., 2013. Monitoring Guidance for Marine Litter in European Seas. MSFD GES Technical Subgroup on Marine Litter (TSG-ML).
- Gramolini R., Mannini P., Milone N., Zeuli V. 2005. AdriaMed Trawl Survey Information System (ATrIS):User manual. FAO-MiPAF Scientific Cooperation to support Responsible Fisheries in the Adriatic Sea.GCP/RER/010/ITA/TD-17.
- Horton, T.; Kroh, A.; Ahyong, S.; et al. (2019). World Register of Marine Species. Available from <http://www.marinespecies.org> at VLIZ. Accessed 2019-05-24. doi:10.14284/170
- ICES 2010. Report of the Workshop on Sexual Maturity Staging of sole, plaice, dab and flounder (WKMSSPDF), 22-26 February 2010, Ijmuiden, The Netherlands. ICES 2010/ACOM:50. 96 pp.
- ICES. 2012a. Report of the Working Group on Integrating Surveys for the Ecosystem Approach (WGISUR), 24-26 January 2012, Ijmuiden, the Netherlands. ICES CM 2012/SSGESST:20. 24 pp.
- ICES. 2012b. Manual for the International Bottom Trawl Surveys. Series of ICES Survey Protocols. SISP 1-IBTS VIII. 68 pp
- ICES, 2012c. Report of the Workshop2 on Sexual Maturity Staging of sole, plaice, dab and flounder (WKMSSPDF2). ICES CM 2012/ACOM:55. 64 pp
- ICES. 2018. Interim Report of the Working Group on Marine Litter (WGML), 23–27 April 2018, ICES Headquarters, Copenhagen, Denmark. ICES CM 2018/HAPISG: 10. 90 pp
- IRPEM – CNR 1996. Growth and behaviour of *Squilla mantis* (mantis shrimp) in the Adriatic Sea. Study contract XIV/MED/93/016. Final report. 74 pp.
- MEDITS 2016. Version n. 8, 2016, MEDITS Working Group: 177 pp
- MEDITS 2017 - International bottom trawl survey in the Mediterranean. Handbook. Version 9. 2017, MEDITS Working Group : 106 pp.

[6] ANNEXES

ANNEX I. Technical specifications of the *rapido* trawl used in SoleMon survey.

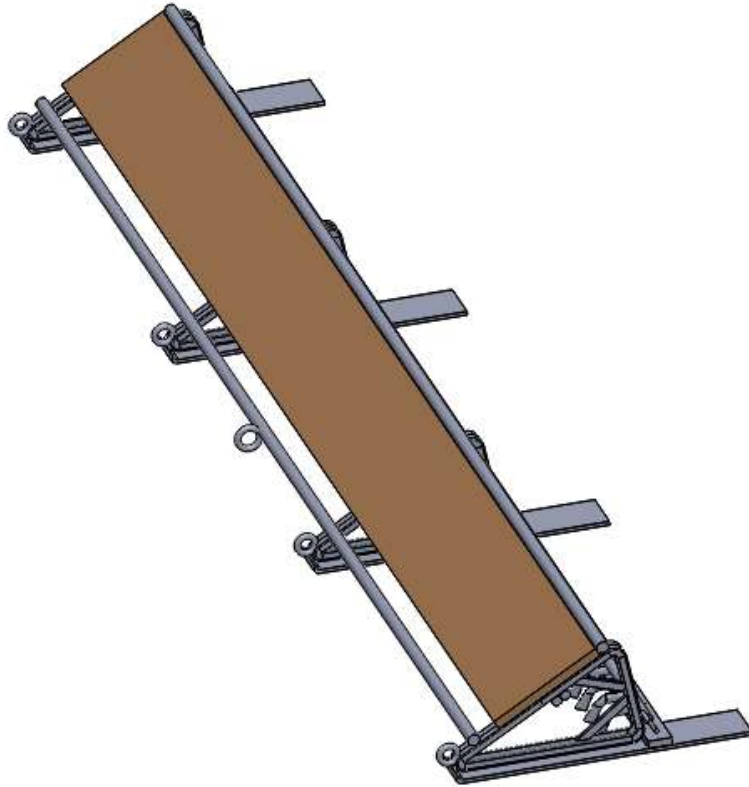

Rapido trawl frame. View from above (Image courtesy of Emilio Notti).



Rapido trawl frame. Lateral-back side view. The undersurface of the central sledges stands 1 cm over the lateral sledges (Image courtesy of Emilio Notti).

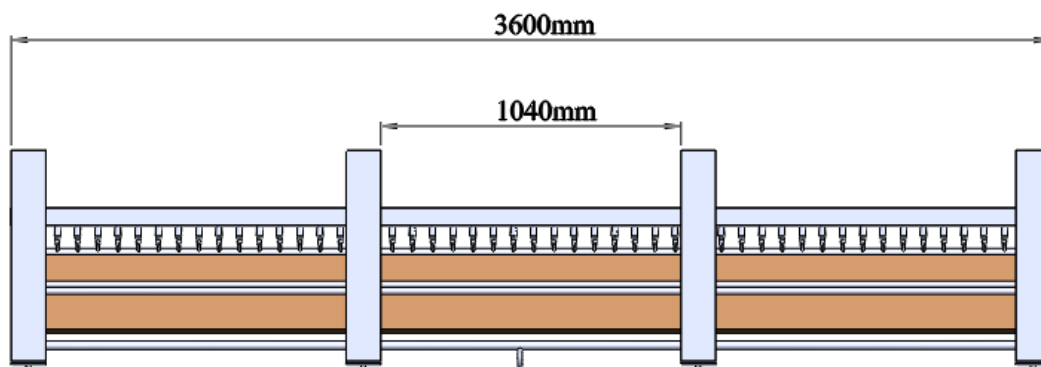

Rapido trawl frame scheme. View from the bottom (Image courtesy of Emilio Notti).

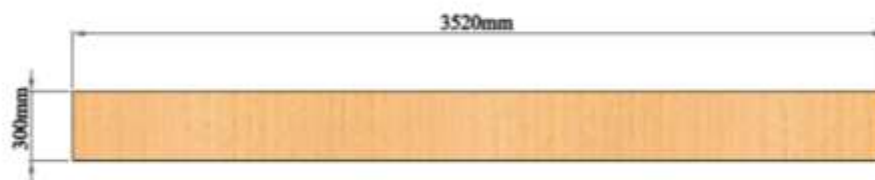

Rapido trawl deflector (20 mm height) (Image courtesy of Emilio Notti).



Rapido trawl. Bar length (Image courtesy of Emilio Notti).



Rapido trawl. Bar diameter (Image courtesy of Emilio Notti).

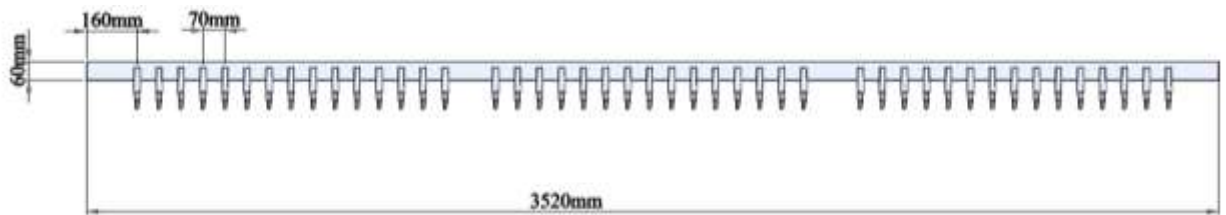

Rapido trawl blade. View from above: 3 rows of teeth, 15 teeth per row (Image courtesy of Emilio Notti).

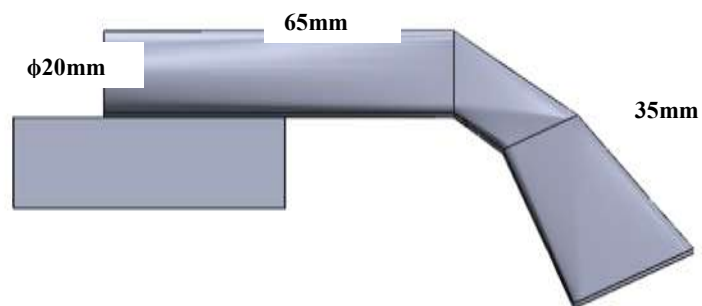

Rapido trawl blade. Lateral view. Square end of the knife 1 cm below the undersurface of the sledge (Image courtesy of Emilio Notti).

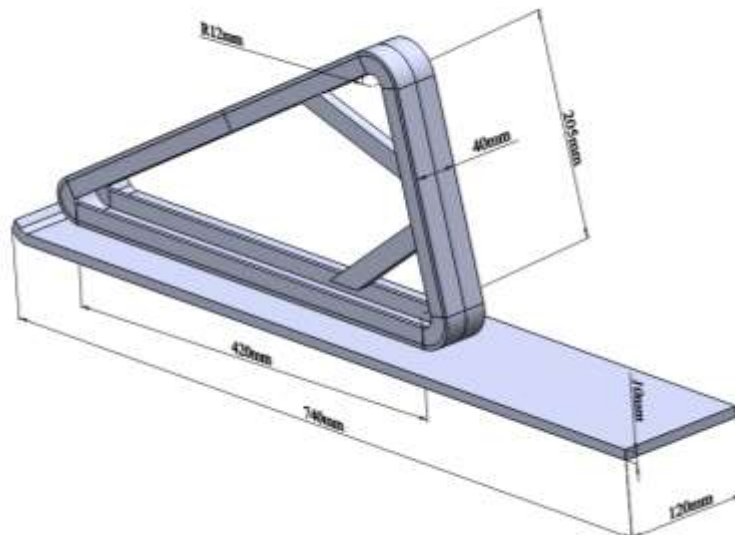

Rapido trawl. Sledge dimensions (Image courtesy of Emilio Notti).

ANNEX II. Representative photographs of litter items.

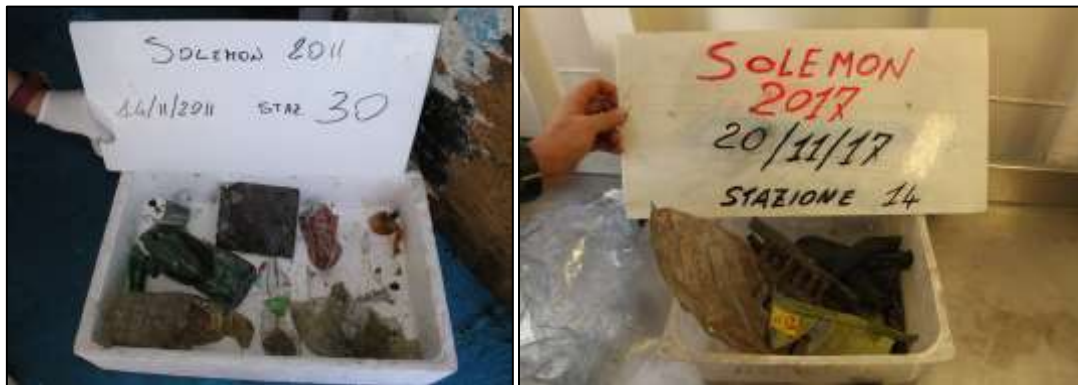

Litter overview			
A: Plastic	B: Sanitary waste	C: Metal	Related size category
A1. Bottle	B1. Diapers	C1. Cans (food)	A: <5*5 cm= 25 cm ²
A2. Sheets, indus. packaging, plastic sheeting	B2. Cotton buds	C2. Cans (beverage)	B: <10*10 cm= 100 cm ²
A3. Bag	B3. Cigarette butts	C3. Fishing related (weights, hooks, sinkers, lures)	C: <20*20 cm= 400 cm ²
A4. Caps/lids	B4. Condoms	C4. Drums	D: <50*50 cm= 2500 cm ²
A5. Fishing line (monofilament)	B5. Syringes	C5. Appliances (refrigerators, washers, etc.)	E: <100*100 cm= 10000 cm ² = 1 m ²
A6. Fishing line (entangled)	B6. Sanitary towels/tampon	C6. Car parts	F: >100*100 cm = 10000 cm ² = 1 m ²
A7. Synthetic rope	B7. Other sanitary waste	C7. Cables	
A8. Fishing net		C8. Other metal	
A9. Cable ties		C9. Middle size containers (of paint, oil, chemicals)	
A10. Strapping band		C10. Large metallic objects	
A11. Crates and containers			
A12. Mussel farming ropes			
A13. Other plastic			
A14. Food containers/wrappers			
A15. Other fishing related (pots, floats, etc.)			
D: Rubber	E: Glass/Ceramic	F: Natural products	G: Miscellaneous
D1. Boots	E1. Jar	F1. Wood (processed)	G1. Clothing/rags
D2. Balloons and balloon sticks	E2. Bottle	F2. Rope	G2. Shoes
D3. Bobbins (fishing)	E3. Piece	F3. Paper/cardboard	G3. Other miscellaneous
D4. Tyre	E4. Other glass/ceramics	F4. Pallets	G4. Carpet & Furnishing
D5. Glove		F5. Other natural products	G5. Other textiles
D6. Other rubber			

Litter Record Sheet							
Cruise:	Station:		Date:				
Litter Type (A1; B2; C...)	Description (Label/ Brand)	Size category (A; B; C...)	Weight (kg)	Number	attached organisms (yes/no)	Taxonomy Info	Comments (Item description if other under litter type)

Conversion table of the codes used in different seafloor litter monitoring protocols.

DESCRIPTION (SOLEMON)	MATERIAL	SOLEMON_CODE	MEDITS_C ODE	TG-ML_CODE	IBTS_C ODE
Bags	ARTIFICIAL POLYMER MATERIALS	LITA3	L1a.	G2	A3
Bottles	ARTIFICIAL POLYMER MATERIALS	LITA1	L1b.	G6	A1
Food containers/wrappers	ARTIFICIAL POLYMER MATERIALS	LITA14	L1c.	G10	
Crates and containers	ARTIFICIAL POLYMER MATERIALS	LITA11	L1e.	G18	A11
Caps/lids	ARTIFICIAL POLYMER MATERIALS	LITA4		G20	A4
Cigarette butts	ARTIFICIAL POLYMER MATERIALS	LITB3		G27	
Gloves	ARTIFICIAL POLYMER MATERIALS	LITD5		G39	C5
Mussel farm ropes	ARTIFICIAL POLYMER MATERIALS	LITA12		G45	
Synthetic rope	ARTIFICIAL POLYMER MATERIALS	LITA7	L1i.	G48	A7
Fishing nets	ARTIFICIAL POLYMER MATERIALS	LITA8	L1f.	G51	A8
Fishing lines (entangled)	ARTIFICIAL POLYMER MATERIALS	LITA6	L1g.	G55	A6
Fishing lines (monofilament)	ARTIFICIAL POLYMER MATERIALS	LITA5		G59	A5
Other fishing-related (pots, floats, etc.)	ARTIFICIAL POLYMER MATERIALS	LITA15	L1h.	G61	
Strapping bands	ARTIFICIAL POLYMER MATERIALS	LITA10		G66	A10
Sheets	ARTIFICIAL POLYMER MATERIALS	LITA2	L1d.	G67	A2
Cable ties	ARTIFICIAL POLYMER MATERIALS	LITA9		G93	A9
Cotton buds	ARTIFICIAL POLYMER MATERIALS	LITB2		G95	
Sanitary towels/tampons	ARTIFICIAL POLYMER MATERIALS	LITB6		G96	A13
Diapers	ARTIFICIAL POLYMER MATERIALS	LITB1	L5d.	G98	A12
Syringes	ARTIFICIAL POLYMER MATERIALS	LITB5		G99	
Other plastic	ARTIFICIAL POLYMER MATERIALS	LITA13	L1	G124	A14
Balloons and balloon sticks	RUBBER	LITD2		G125	C2
Boots	RUBBER	LITD1		G127	C1
Tyres	RUBBER	LITD4	L2a.	G128	C4
Bobbins (fishing)	RUBBER	LITD3		G132	C3
Condoms	RUBBER	LITB4		G133	
Other rubber	RUBBER	LITD6	L2	G134	C6
Shoes	CLOTH/TEXTILE	LITG2		G136	F2
Clothing/rags	CLOTH/TEXTILE	LITG1	L5a.	G137	F1
Carpets & Furnishings	CLOTH/TEXTILE	LITG4	L5b.	G141	
Rope	CLOTH/TEXTILE	LITF2	L5c.	G142	E2
Other textiles	CLOTH/TEXTILE	LITG5	L5	G145	F3
Paper/cardboard	PAPER/CARDBOARD PROCESSED/WORKED	LITF3	L7	G146	E3
Pallets	WOOD PROCESSED/WORKED	LITF4		G160	E4
Wood (processed)	WOOD PROCESSED/WORKED	LITF1	L6	G170	E1
Other natural products	WOOD	LITF5		G173	E5
Cans (beverages)	METAL	LITC2	L3a.	G175	B2

DESCRIPTION (SOLEMON)	MATERIAL	SOLEMON_ CODE	MEDITS_ ODE	TG- ML_CODE	IBTS_ ODE
Cans (food)	METAL	LITC1	L3b.	G176	B1
Appliances	METAL	LITC5	L3d.	G180	B5
Fishing-related (weights, hooks, sinkers, lures)	METAL	LITC3	L3f.	G182	B3
Middle-sized containers (of paint, oil, chemicals)	METAL	LITC9	L3c.	G185	
Drums	METAL	LITC4		G187	B4
Car parts	METAL	LITC6		G193	B6
Cables	METAL	LITC7	L3e.	G194	B7
Large metal objects	METAL	LITC10		G196	
Other metals	METAL	LITC8	L3	G197	B8
Bottles	GLASS/CERAMICS	LITE2	L4a.	G200	D2
Jars	GLASS/CERAMICS	LITE1	L4c.	G201	D1
Fragments	GLASS/CERAMICS	LITE3	L4b.	G208	D3
Other glass/ceramic	GLASS/CERAMICS	LITE4	L4	G210	D4
Other miscellaneous	MIX	LITG3	L2b.		
Other sanitary waste	MIX	LITB7			

ANNEX III. Codes of faunistic categories and list of species.

Codes of faunistic categories

Faunistic category	Taxon 1	Taxon 2	Nature		Year of introduction
A	<i>Fishes and elasmobranch</i>				
A	VER	ELA	Vertebrata	Elasmobranchii	2005
A	VER	ACT	Vertebrata	Actinopterygii	2005
B	<i>Crustaceans (edible)</i>				
B	CRO	DEC	Crustacea	Malacostraca (Decapoda)	2005
B	CRO	STO	Crustacea	Malacostraca (Stomatopoda)	2005
C	<i>Cephalopods</i>				
C	MOL	MYO	Mollusca	Cephalopoda (Myopsida)	2005
C	MOL	OEG	Mollusca	Cephalopoda (Oegopsida)	2005
C	MOL	SEP	Mollusca	Cephalopoda (Sepiida)	2005
C	MOL	OCT	Mollusca	Cephalopoda (Octopoda)	2005
D	<i>Other Edible species</i>				
D	MOL	BIV	Mollusca	Bivalvia	2005
D	MOL	GAS	Mollusca	Gastropoda	2007
E	<i>Other non-edible species</i>				
E	ANN	CLI	Annelida	Clitellata	2007
E	ANN	POL	Annelida	Polychaeta	2007
E	BRY	STE	Bryozoa	Stenolaemata	2018
E	BRY	GYM	Bryozoa	Gymnolaemata	2007
E	CNI	ANT	Cnidaria	Anthozoa	2007
E	CNI	HYD	Cnidaria	Hydrozoa	2007
E	CNI	SCY	Cnidaria	Scyphozoa	2017
E	CRO	HEX	Crustacea	Hexanauplia	2007
E	CRO	DEC	Crustacea	Malacostraca (Decapoda)	2005
E	CRO	ISO	Crustacea	Malacostraca (Isopoda)	2007
E	CTE	TEN	Ctenophora	Tentaculata	2015
E	ECH	AST	Echinodermata	Asteroidea	2007
E	ECH	CRI	Echinodermata	Crinoidea	2007
E	ECH	ECH	Echinodermata	Echinoidea	2007
E	ECH	HOL	Echinodermata	Holoturoidea	2007
E	ECH	OPH	Echinodermata	Ophiuroidea	2007
E	MOL	BIV	Mollusca	Bivalvia	2005
E	MOL	GAS	Mollusca	Gastropoda	2005
E	MOL	PLA	Mollusca	Polyplacophora	2007
E	MOL	SCA	Mollusca	Scaphopoda	2007
E	POR	DEM	Porifera	Demospongiae	2007
E	PLA	PLA	Platyhelminthes		2011
E	SIP	SIP	Sipuncula	Sipunculidea	2007
E	TUN	ASC	Tunicata	Ascidiacea	2007
G	<i>Portions or products of animal species, organogenic concretions etc.</i>				
H	<i>Portion of vegetal species</i>				
L	<i>Litter</i>				
R	<i>Reptiles</i>				
R	VER	REP	Vertebrata	Reptilia	2010

Faunistic category	Taxon 1	Taxon 2	Nature	Year of introduction	
V	<i>Plantae</i>				
V	TRA	LIL	Tracheophyta	Magnoliopsida	2013

List of species and codification

SoleMon Code	Name	Faunistic category	Taxon 1	Taxon 2	Year of introduction
	<i>Fishes and elasmobranch</i>				
ANGUANG	<i>Anguilla anguilla</i>	A	VER	ACT	2005
ANTOMEG	<i>Gaidropsarus biscayensis</i>	A	VER	ACT	2007
ARGESPY	<i>Argentina sphyraena</i>	A	VER	ACT	2005
ARIOBAL	<i>Ariosoma balearicum</i>	A	VER	ACT	2005
ARNOIMP	<i>Arnoglossus imperialis</i>	A	VER	ACT	2005
ARNOLAT	<i>Arnoglossus laterna</i>	A	VER	ACT	2012
ARNORUP	<i>Arnoglossus rueppelii</i>	A	VER	ACT	2005
ARNOTHO	<i>Arnoglossus thori</i>	A	VER	ACT	2005
ASPICUC	<i>Chelidonichthys cuculus</i>	A	VER	ACT	2005
ATHEBOY	<i>Atherina boyeri</i>	A	VER	ACT	2008
ATHEHEP	<i>Atherina hepsetus</i>	A	VER	ACT	2015
BALICAR	<i>Balistes capriscus</i>	A	VER	ACT	2005
BLENGAT	<i>Parablennius gattorugine</i>	A	VER	ACT	2007
BLENOCE	<i>Blennius ocellaris</i>	A	VER	ACT	2007
BLENTEN	<i>Parablennius tentacularis</i>	A	VER	ACT	2007
BOOPBOO	<i>Boops boops</i>	A	VER	ACT	2005
BOTHPOD	<i>Bothus podas</i>	A	VER	ACT	2005
BUGLLUT	<i>Buglossidium luteum</i>	A	VER	ACT	2005
CALLISP	<i>Callionymus sp.</i>	A	VER	ACT	2007
CALMMAC	<i>Callionymus maculatus</i>	A	VER	ACT	2007
CALMRIS	<i>Callionymus risso</i>	A	VER	ACT	2007
CARPACU	<i>Carapus acus</i>	A	VER	ACT	2007
CEPOMAC	<i>Cepola macrophthalmia</i>	A	VER	ACT	2007
CITHMAC	<i>Citharus linguatula</i>	A	VER	ACT	2012
CONGCON	<i>Conger conger</i>	A	VER	ACT	2005
DALOIMB	<i>Dalophis imberbis</i>	A	VER	ACT	2005
DICELAB	<i>Dicentrarchus labrax</i>	A	VER	ACT	2005
DIPLANN	<i>Diplodus annularis</i>	A	VER	ACT	2005
DIPLVUL	<i>Diplodus vulgaris</i>	A	VER	ACT	2005
ENGRENC	<i>Engraulis encrasicolus</i>	A	VER	ACT	2005
EUTRGUR	<i>Eutrigla gurnardus</i>	A	VER	ACT	2005
GADUMER	<i>Merlangius merlangus</i>	A	VER	ACT	2005
GAIDMED	<i>Gaidropsarus mediterraneus</i>	A	VER	ACT	2007
GNATMYS	<i>Gnathophis mystax</i>	A	VER	ACT	2005
GOBICOL	<i>Deltentosteus collonianus</i>	A	VER	ACT	2005
GOBIFRI	<i>Lesueurigobius friesii</i>	A	VER	ACT	2007
GOBINIG	<i>Gobius niger</i>	A	VER	ACT	2005
GOBIQUA	<i>Deltentosteus quadrimaculatus</i>	A	VER	ACT	2007
GOBISPP	<i>Gobius spp.</i>	A	VER	ACT	2007
GOBISUE	<i>Lesueurigobius suerii</i>	A	VER	ACT	2007
HIPPGUT	<i>Hippocampus guttulatus</i>	A	VER	ACT	2013
HIPPHIC	<i>Hippocampus hippocampus</i>	A	VER	ACT	2007

SoleMon Code	Name	Faunistic category	Taxon 1	Taxon 2	Year of introduction
LEPICAU	<i>Lepidopus caudatus</i>	A	VER	ACT	2005
LEPMBOS	<i>Lepidorhombus boscii</i>	A	VER	ACT	2005
LEPMWHS	<i>Lepidorhombus whiffiagonis</i>	A	VER	ACT	2005
LEPTCAV	<i>Lepidotrigla cavillone</i>	A	VER	ACT	2005
LESUSAN	<i>Lesueurigobius sanzi</i>	A	VER	ACT	2007
LITHMOR	<i>Lithognathus mormyrus</i>	A	VER	ACT	2005
LIZAAUR	<i>Chelon auratus</i>	A	VER	ACT	2005
LIZARAM	<i>Chelon ramada</i>	A	VER	ACT	2007
LIZASAL	<i>Chelon saliens</i>	A	VER	ACT	2005
LOPHBUD	<i>Lophius budegassa</i>	A	VER	ACT	2005
LOPHPIS	<i>Lophius piscatorius</i>	A	VER	ACT	2005
MERLMER	<i>Merluccius merluccius</i>	A	VER	ACT	2005
MICMPOU	<i>Micromesistius poutassou</i>	A	VER	ACT	2005
MICUOCE	<i>Microchirus ocellatus</i>	A	VER	ACT	2005
MICUVAR	<i>Microchirus variegatus</i>	A	VER	ACT	2012
MONOHIS	<i>Monochirus hispidus</i>	A	VER	ACT	2005
MULLBAR	<i>Mullus barbatus barbatus</i>	A	VER	ACT	2005
MULLSUR	<i>Mullus surmuletus</i>	A	VER	ACT	2005
OPDIBAR	<i>Ophidion barbatum</i>	A	VER	ACT	2007
OPHCRUF	<i>Ophichthus rufus</i>	A	VER	ACT	2005
PAGEACA	<i>Pagellus acarne</i>	A	VER	ACT	2005
PAGEBOG	<i>Pagellus bogaraveo</i>	A	VER	ACT	2005
PAGEERY	<i>Pagellus erythrinus</i>	A	VER	ACT	2005
PHRYREG	<i>Zeugopterus regius</i>	A	VER	ACT	2007
PHYIBLE	<i>Phycis blennoides</i>	A	VER	ACT	2007
PHYIPHY	<i>Phycis phycis</i>	A	VER	ACT	2007
PLATFLE	<i>Platichthys flesus</i>	A	VER	ACT	2005
POMSMIN	<i>Pomatoschistus minutus</i>	A	VER	ACT	2007
PSETMAX	<i>Scophthalmus maximus</i>	A	VER	ACT	2012
SARDPIL	<i>Sardina pilchardus</i>	A	VER	ACT	2005
SARIAUR	<i>Sardinella aurita</i>	A	VER	ACT	2005
SCOHRHO	<i>Scophthalmus rhombus</i>	A	VER	ACT	2012
SCOMSCO	<i>Scomber scombrus</i>	A	VER	ACT	2005
SCORNOT	<i>Scorpaena notata</i>	A	VER	ACT	2005
SCORPOR	<i>Scorpaena porcus</i>	A	VER	ACT	2005
SCORSCO	<i>Scorpaena scrofa</i>	A	VER	ACT	2005
SERAATR	<i>Serranus atricauda</i>	A	VER	ACT	2005
SERACAB	<i>Serranus cabrilla</i>	A	VER	ACT	2005
SERAHEP	<i>Serranus hepatus</i>	A	VER	ACT	2005
SERASCR	<i>Serranus scriba</i>	A	VER	ACT	2005
SOLEAEG	<i>Solea aegyptiaca</i>	A	VER	ACT	2011
SOLEIMP	<i>Pegusa impar</i>	A	VER	ACT	2007
SOLEKLE	<i>Synapturichthys kleinii</i>	A	VER	ACT	2007
SOLELAS	<i>Pegusa lascaris</i>	A	VER	ACT	2007
SOLEVUL	<i>Solea solea</i>	A	VER	ACT	2012
SPARAUR	<i>Sparus aurata</i>	A	VER	ACT	2005
SPARPAG	<i>Pagrus pagrus</i>	A	VER	ACT	2005
SPHYSPY	<i>Sphyræna sphyraena</i>	A	VER	ACT	2005
SPICFLE	<i>Spicara flexuosa</i>	A	VER	ACT	2005
SPICMAE	<i>Spicara maena</i>	A	VER	ACT	2005
SPIC SMA	<i>Spicara smaris</i>	A	VER	ACT	2005
SPODCAN	<i>Spondyliosoma cantharus</i>	A	VER	ACT	2005
SPRASPR	<i>Sprattus sprattus</i>	A	VER	ACT	2005
SYMDCIN	<i>Symphodus cinereus</i>	A	VER	ACT	2005

SoleMon Code	Name	Faunistic category	Taxon 1	Taxon 2	Year of introduction
SYMDOCE	<i>Symphodus ocellatus</i>	A	VER	ACT	2005
SYMPNIG	<i>Symphurus nigrescens</i>	A	VER	ACT	2005
SYNGABA	<i>Syngnathus abaster</i>	A	VER	ACT	2019
SYNGACU	<i>Syngnathus acus</i>	A	VER	ACT	2007
SYNGTAE	<i>Syngnathus taenionotus</i>	A	VER	ACT	2005
TRACMED	<i>Trachurus mediterraneus</i>	A	VER	ACT	2005
TRACTRA	<i>Trachurus trachurus</i>	A	VER	ACT	2005
TRAHARA	<i>Trachinus araneus</i>	A	VER	ACT	2005
TRAHDRA	<i>Trachinus draco</i>	A	VER	ACT	2005
TRIGLUC	<i>Chelidonichthys lucerna</i>	A	VER	ACT	2012
TRIGLYR	<i>Trigla lyra</i>	A	VER	ACT	2005
TRIPLAS	<i>Chelidonichthys lastoviza</i>	A	VER	ACT	2005
TRISCAP	<i>Trisopterus capelanus</i>	A	VER	ACT	2005
UMBRCIR	<i>Umbrina cirrosa</i>	A	VER	ACT	2005
URANSCA	<i>Uranoscopus scaber</i>	A	VER	ACT	2005
ZEUSFAB	<i>Zeus faber</i>	A	VER	ACT	2007
MUSTPUN	<i>Mustelus punctulatus</i>	A	VER	ELA	2006
MYLIAQU	<i>Myliobatis aquila</i>	A	VER	ELA	2005
PTERVIO	<i>Pteroplatytrygon violacea</i>	A	VER	ELA	2007
RAJAAST	<i>Raja asterias</i>	A	VER	ELA	2005
RAJABRA	<i>Raja brachyura</i>	A	VER	ELA	2005
RAJACLA	<i>Raja clavata</i>	A	VER	ELA	2005
RAJAMIR	<i>Raja miraletus</i>	A	VER	ELA	2005
RAJAMON	<i>Raja montagui</i>	A	VER	ELA	2005
SCYOCAN	<i>Scyliorhinus canicula</i>	A	VER	ELA	2005
SCYOSTE	<i>Scyliorhinus stellaris</i>	A	VER	ELA	2005
TORPMAR	<i>Torpedo marmorata</i>	A	VER	ELA	2005
TORPNOB	<i>Tetronarce nobiliana</i>	A	VER	ELA	2005
TORPTOR	<i>Torpedo torpedo</i>	A	VER	ELA	2005
	Crustaceans (Edible)				
HOMAGAM	<i>Homarus gammarus</i>	B	CRO	DEC	2007
MAJACRI	<i>Maja crispata</i>	B	CRO	DEC	2007
MAJASQU	<i>Maja squinado</i>	B	CRO	DEC	2005
MELIKER	<i>Penaeus kerathurus</i>	B	CRO	DEC	2012
NEPRNOR	<i>Nephrops norvegicus</i>	B	CRO	DEC	2005
PAPELON	<i>Parapenaeus longirostris</i>	B	CRO	DEC	2005
SQUIMAN	<i>Squilla mantis</i>	B	CRO	STO	2005
	Cephalopods				
ALLOMED	<i>Alloteuthis media</i>	C	MOL	MYO	2005
ALLOSUB	<i>Alloteuthis subulata</i>	C	MOL	MYO	2005
LOLIVUL	<i>Loligo vulgaris</i>	C	MOL	MYO	2005
ELEDCIR	<i>Eledone cirrhosa</i>	C	MOL	OCT	2006
ELEDMOS	<i>Eledone moschata</i>	C	MOL	OCT	2005
OCTOVUL	<i>Octopus vulgaris</i>	C	MOL	OCT	2005
ILLECOI	<i>Illex coindetii</i>	C	MOL	OEG	2005
TODASAG	<i>Todarodes sagittatus</i>	C	MOL	OEG	2005
TODIEBL	<i>Todaropsis eblanae</i>	C	MOL	OEG	2005
ROSSMAC	<i>Rossia macrosoma</i>	C	MOL	SEP	2005
SEPIELE	<i>Sepia elegans</i>	C	MOL	SEP	2005
SEPIOFF	<i>Sepia officinalis</i>	C	MOL	SEP	2012
SEPIORB	<i>Sepia orbignyana</i>	C	MOL	SEP	2005
SEPORON	<i>Sepioloa rondeletii</i>	C	MOL	SEP	2005

SoleMon Code	Name	Faunistic category	Taxon 1	Taxon 2	Year of introduction
Other edible species					
AEQUOPE	<i>Aequipecten opercularis</i>	D	MOL	BIV	2012
CALLCHI	<i>Callista chione</i>	D	MOL	BIV	2007
CHAMGAL	<i>Chamelea gallina</i>	D	MOL	BIV	2007
CHLAGLA	<i>Flexopecten glaber</i>	D	MOL	BIV	2007
MODIBAR	<i>Modiolus barbatus</i>	D	MOL	BIV	2007
MYTGALL	<i>Mytilus galloprovincialis</i>	D	MOL	BIV	2009
OSTREDU	<i>Ostrea edulis</i>	D	MOL	BIV	2005
PECTJAC	<i>Pecten jacobaeus</i>	D	MOL	BIV	2012
SOLEMAR	<i>Solen marginatus</i>	D	MOL	BIV	2008
VENUVER	<i>Venus verrucosa</i>	D	MOL	BIV	2007
APORPES	<i>Aporrhais pespelecani</i>	D	MOL	GAS	2007
GALEECH	<i>Galeodea echinophora</i>	D	MOL	GAS	2007
HEXATRU	<i>Hexaplex trunculus</i>	D	MOL	GAS	2007
MUREBRA	<i>Bolinus brandaris</i>	D	MOL	GAS	2007
NASSMUT	<i>Tritia mutabilis</i>	D	MOL	GAS	2007
NASSSPP	<i>Nassariidae spp.</i>	D	MOL	GAS	2007
NATISPP	<i>Naticidae spp.</i>	D	MOL	GAS	2007
NATISTE	<i>Naticarius stercusmuscarum</i>	D	MOL	GAS	2007
RAPAVEN	<i>Rapana venosa</i>	D	MOL	GAS	2007
Other non-edible species					
PONTMUR	<i>Pontobdella muricata</i>	E	ANN	CLI	2007
APHRACU	<i>Aphrodita aculeata</i>	E	ANN	POL	2007
APHRSP	<i>Aphroditidae spp.</i>	E	ANN	POL	2015
BONEVIR	<i>Bonellia viridis</i>	E	ANN	POL	2016
FILOGSP	<i>Filograna sp.</i>	E	ANN	POL	2014
GLYCESP	<i>Glycera sp.</i>	E	ANN	POL	2013
HERMHIS	<i>Laetmonice hystrix</i>	E	ANN	POL	2012
HYALTUB	<i>Hyalinoecia tubicola</i>	E	ANN	POL	2007
MAXMLAN	<i>Maxmuelleria lankesteri</i>	E	ANN	POL	2018
NEPHSPP	<i>Nephtys spp.</i>	E	ANN	POL	2012
OWENFUS	<i>Owenia fusiformis</i>	E	ANN	POL	2007
POMATRI	<i>Spirobranchus triqueter</i>	E	ANN	POL	2012
SABEPAV	<i>Sabella pavonina</i>	E	ANN	POL	2016
SABESPA	<i>Sabella spallanzanii</i>	E	ANN	POL	2016
SERPSP	<i>Serpulidae spp.</i>	E	ANN	POL	2017
SERPVER	<i>Serpula vermicularis</i>	E	ANN	POL	2007
STERSCU	<i>Sternaspis scutata</i>	E	ANN	POL	2007
AMATHSE	<i>Amathia semiconvoluta</i>	E	BRY	GYM	2012
CELLASP	<i>Cellaria sp.</i>	E	BRY	GYM	2007
CELLSAL	<i>Cellaria salicornioides</i>	E	BRY	GYM	2007
PORECER	<i>Smittina cervicornis</i>	E	BRY	GYM	2007
PORELSP	<i>Porella sp.</i>	E	BRY	GYM	2007
RETEBEA	<i>Reteporella beaniana</i>	E	BRY	GYM	2015
SCHISAN	<i>Schizobrachiella sanguinea</i>	E	BRY	GYM	2007
SCHYPSP	<i>Schizoporella sp.</i>	E	BRY	GYM	2011
HORNSP	<i>Hornera spp.</i>	E	BRY	STE	2018
ADAMCAR	<i>Adamsia palliata</i>	E	CNI	ANT	2007
ADAMSSP	<i>Adamsia spp.</i>	E	CNI	ANT	2013
ALCYPAL	<i>Alcyonium palmatum</i>	E	CNI	ANT	2007
BALAEUR	<i>Balanophyllia (Balanophyllia) europaea</i>	E	CNI	ANT	2015
CALLPAR	<i>Calliactis parasitica</i>	E	CNI	ANT	2007
CARYOSP	<i>Caryophyllia sp.</i>	E	CNI	ANT	2007

SoleMon Code	Name	Faunistic category	Taxon 1	Taxon 2	Year of introduction
CEREPED	<i>Cereus pedunculatus</i>	E	CNI	ANT	2013
CLADCAE	<i>Cladocora caespitosa</i>	E	CNI	ANT	2007
EPIZSPP	<i>Epizoanthus spp.</i>	E	CNI	ANT	2007
FUNIQUA	<i>Funiculina quadrangularis</i>	E	CNI	ANT	2012
PENNPFO	<i>Pennatula phosphorea</i>	E	CNI	ANT	2007
PENNRUB	<i>Pennatula rubra</i>	E	CNI	ANT	2007
PTERSPI	<i>Pteroeides spinosum</i>	E	CNI	ANT	2007
VIRGMIR	<i>Virgularia mirabilis</i>	E	CNI	ANT	2007
LYTOCSP	<i>Lytocarpia sp.</i>	E	CNI	HYD	2007
LYTOMYR	<i>Lytocarpia myriophyllum</i>	E	CNI	HYD	2007
NEMERAN	<i>Nemertesia antennina</i>	E	CNI	HYD	2007
NEMERSP	<i>Nemertesia sp.</i>	E	CNI	HYD	2007
NEMESPP	<i>Nemertea spp.</i>	E	CNI	HYD	2012
RHIZPUL	<i>Rhizostoma pulmo</i>	E	CNI	SCI	2017
AEGECAT	<i>Aegaeon cataphractus</i>	E	CRO	DEC	2017
ALPHDEN	<i>Alpheus dentipes</i>	E	CRO	DEC	2011
ALPHGLA	<i>Alpheus glaber</i>	E	CRO	DEC	2007
ALPHMAC	<i>Alpheus macrocheles</i>	E	CRO	DEC	2012
ANAPASP	<i>Anapagurus sp.</i>	E	CRO	DEC	2012
ANAPBIC	<i>Anapagurus bicorniger</i>	E	CRO	DEC	2007
ANAPBRE	<i>Anapagurus breviaculeatus</i>	E	CRO	DEC	2007
ANAPLAE	<i>Anapagurus laevis</i>	E	CRO	DEC	2005
ASCIFLA	<i>Ascidonia flavomaculata</i>	E	CRO	DEC	2012
ATELROT	<i>Atelecyclus rotundatus</i>	E	CRO	DEC	2007
BATHLON	<i>Bathynectes longipes</i>	E	CRO	DEC	2012
BATHYSP	<i>Bathynectes sp.</i>	E	CRO	DEC	2013
BRACGEM	<i>Brachynotus gemmellaroi</i>	E	CRO	DEC	2012
BRACSPP	<i>Brachynotus spp.</i>	E	CRO	DEC	2013
CALAGRA	<i>Calappa granulata</i>	E	CRO	DEC	2005
CARCAES	<i>Carcinus aestuarii</i>	E	CRO	DEC	2007
CHLOGRA	<i>Chlorotocus crassicornis</i>	E	CRO	DEC	2007
CORYCAS	<i>Corystes cassivelaunus</i>	E	CRO	DEC	2007
DARDARR	<i>Dardanus arrosor</i>	E	CRO	DEC	2007
DARDCAL	<i>Dardanus calidus</i>	E	CRO	DEC	2007
DIOGPUG	<i>Diogenes pugilator</i>	E	CRO	DEC	2007
DROMPER	<i>Dromia personata</i>	E	CRO	DEC	2007
DYSPASP	<i>Dyspanopeus sp.</i>	E	CRO	DEC	2014
DYSPSAY	<i>Dyspanopeus sayi</i>	E	CRO	DEC	2016
EBALCRA	<i>Ebalia cranchii</i>	E	CRO	DEC	2007
EBALEDW	<i>Ebalia deshayesi</i>	E	CRO	DEC	2012
ERIPVER	<i>Eriphia verrucosa</i>	E	CRO	DEC	2013
ETHUMAS	<i>Ethusa mascarone</i>	E	CRO	DEC	2007
EURYASP	<i>Eurynome aspera</i>	E	CRO	DEC	2007
GALADIS	<i>Galathea dispersa</i>	E	CRO	DEC	2007
GALAINI	<i>Galathea intermedia</i>	E	CRO	DEC	2007
GALANEX	<i>Galathea nexa</i>	E	CRO	DEC	2007
GONERHO	<i>Goneplax rhomboides</i>	E	CRO	DEC	2007
ILIANUC	<i>Ilia nucleus</i>	E	CRO	DEC	2007
INACCOM	<i>Inachus communissimus</i>	E	CRO	DEC	2007
INACDOR	<i>Inachus dorsettensis</i>	E	CRO	DEC	2007
INACLEP	<i>Inachus leptochirus</i>	E	CRO	DEC	2014
INACTHO	<i>Inachus thoracicus</i>	E	CRO	DEC	2007
JAXENOC	<i>Jaxea nocturna</i>	E	CRO	DEC	2007
LIOCCOR	<i>Liocarcinus corrugatus</i>	E	CRO	DEC	2015

SoleMon Code	Name	Faunistic category	Taxon 1	Taxon 2	Year of introduction
LIOCDEP	<i>Liocarcinus depurator</i>	E	CRO	DEC	2007
LIOCVER	<i>Liocarcinus vernalis</i>	E	CRO	DEC	2007
MACRCZE	<i>Macropodia czernjawska</i>	E	CRO	DEC	2012
MACRLIN	<i>Macropodia linaresi</i>	E	CRO	DEC	2007
MACRLNR	<i>Macropodia longirostris</i>	E	CRO	DEC	2007
MACRLON	<i>Macropodia longipes</i>	E	CRO	DEC	2007
MACRROS	<i>Macropodia rostrata</i>	E	CRO	DEC	2007
MAJAGOL	<i>Neomaja goltziana</i>	E	CRO	DEC	2018
MCPIMAC	<i>Liocarcinus maculatus</i>	E	CRO	DEC	2007
MEDOLAN	<i>Medorippe lanata</i>	E	CRO	DEC	2007
MONOCOUC	<i>Monodaeus couchii</i>	E	CRO	DEC	2007
MUNIRUG	<i>Munida rugosa</i>	E	CRO	DEC	2005
MUNIRUT	<i>Munida speciosa</i>	E	CRO	DEC	2013
NEPIPIN	<i>Nepinnotheres pinnotheres</i>	E	CRO	DEC	2007
PAGUALA	<i>Pagurus alatus</i>	E	CRO	DEC	2007
PAGUANA	<i>Pagurus anachoretus</i>	E	CRO	DEC	2011
PAGUCUA	<i>Pagurus cuanensis</i>	E	CRO	DEC	2007
PAGUERE	<i>Paguristes eremita</i>	E	CRO	DEC	2007
PAGUEXC	<i>Pagurus excavatus</i>	E	CRO	DEC	2007
PAGUPRI	<i>Pagurus prideaux</i>	E	CRO	DEC	2005
PALAMAC	<i>Palaemon macrodactylus</i>	E	CRO	DEC	2014
PALESER	<i>Palaemon serratus</i>	E	CRO	DEC	2010
PARTANG	<i>Derilambrus angulifrons</i>	E	CRO	DEC	2007
PARTMAS	<i>Parthenopoides massena</i>	E	CRO	DEC	2007
PILUHIR	<i>Pilumnus hirtellus</i>	E	CRO	DEC	2007
PILUSPI	<i>Pilumnus spinifer</i>	E	CRO	DEC	2007
PINNPIS	<i>Pinnotheres pisum</i>	E	CRO	DEC	2007
PISAARN	<i>Pisa armata</i>	E	CRO	DEC	2007
PISAMUS	<i>Pisa muscosa</i>	E	CRO	DEC	2013
PISANOD	<i>Pisa nodipes</i>	E	CRO	DEC	2005
PISILMN	<i>Pisidia longimana</i>	E	CRO	DEC	2012
PISILON	<i>Pisidia longicornis</i>	E	CRO	DEC	2007
PONPSPI	<i>Pontophilus spinosus</i>	E	CRO	DEC	2007
PROCMOD	<i>Processa modica</i>	E	CRO	DEC	2013
RHYTHAR	<i>Rhithropanopeus harrisi</i>	E	CRO	DEC	2016
SCYLARC	<i>Scyllarus arctus</i>	B	CRO	DEC	2007
SICYCAR	<i>Sicyonia carinata</i>	E	CRO	DEC	2014
SOLOMEM	<i>Solenocera membranacea</i>	B	CRO	DEC	2007
TYPTSPO	<i>Typton spongicola</i>	E	CRO	DEC	2007
UPOGTIP	<i>Upogebia tipica</i>	E	CRO	DEC	2007
XANTPHI	<i>Xantho pilipes</i>	E	CRO	DEC	2007
BALANSP	<i>Balanus sp.</i>	E	CRO	HEX	2007
BALAPER	<i>Perforatus perforatus</i>	E	CRO	HEX	2007
SCALSCA	<i>Scalpellum scalpellum</i>	E	CRO	HEX	2007
ANILPHY	<i>Anilocra physodes</i>	E	CRO	ISO	2018
CYMOTRU	<i>Cymodoce truncata</i>	E	CRO	ISO	2007
RISSDES	<i>Rissoides desmaresti</i>	E	CRO	STO	2007
PLEUSP	<i>Pleurobrachia sp.</i>	E	CTE	TEN	2015
ANSEPLA	<i>Anseropoda placenta</i>	E	ECH	AST	2007
ASTEGLA	<i>Marthasterias glacialis</i>	E	ECH	AST	2007
ASTRAUR	<i>Astropecten aranciacus</i>	E	ECH	AST	2007
ASTRIRR	<i>Astropecten irregularis</i>	E	ECH	AST	2007
CHAELO	<i>Chaetaster longipes</i>	E	ECH	AST	2007
ECHISEP	<i>Echinaster (Echinaster) sepositus</i>	E	ECH	AST	2007

SoleMon Code	Name	Faunistic category	Taxon 1	Taxon 2	Year of introduction
LUIDCIL	<i>Luidia ciliaris</i>	E	ECH	AST	2013
LUIDSAR	<i>Luidia sarsii</i>	E	ECH	AST	2015
OPHIFRA	<i>Ophiothrix fragilis</i>	E	ECH	AST	2007
OPHIOPH	<i>Ophiura ophiura</i>	E	ECH	AST	2007
ANTEMED	<i>Antedon mediterranea</i>	E	ECH	CRI	2007
ARBACSP	<i>Arbacia sp.</i>	E	ECH	ECH	2016
BRISATL	<i>Brissopsis atlantica mediterranea</i>	E	ECH	ECH	2012
BRISLYR	<i>Brissopsis lyrifera</i>	E	ECH	ECH	2011
ECHIACU	<i>Gracilechinus acutus</i>	E	ECH	ECH	2007
ECHIMEL	<i>Echinus melo</i>	E	ECH	ECH	2018
PARALIV	<i>Paracentrotus lividus</i>	E	ECH	ECH	2007
PELTPLA	<i>Peltaster placenta</i>	E	ECH	ECH	2007
PSAMMIC	<i>Psammechinus microtuberculatus</i>	E	ECH	ECH	2007
SCHICAN	<i>Ova canalifera</i>	E	ECH	ECH	2007
SPATAPU	<i>Spatangus purpureus</i>	E	ECH	ECH	2007
SPHAGRA	<i>Sphaerechinus granularis</i>	E	ECH	ECH	2007
CUCUKIR	<i>Stereoderma kirchsbergii</i>	E	ECH	HOL	2013
HOLOFOR	<i>Holothuria (Panningothuria) forskali</i>	E	ECH	HOL	2007
HOLOTUB	<i>Holothuria (Holothuria) tubulosa</i>	E	ECH	HOL	2007
LABIPLA	<i>Oestergrenia digitata</i>	E	ECH	HOL	2007
LETPEN	<i>Leptopentacta elongata</i>	E	ECH	HOL	2007
OCNUPLA	<i>Ocnus planci</i>	E	ECH	HOL	2007
PHYLURN	<i>Phyllophorus (Phyllophorus) urna</i>	E	ECH	HOL	2007
STICREG	<i>Parastichopus regalis</i>	E	ECH	HOL	2007
THYOFUS	<i>Thyone fusus</i>	E	ECH	HOL	2011
TRACTER	<i>Leptopentacta tergestina</i>	E	ECH	HOL	2007
AMPHCHI	<i>Amphiura chiajei</i>	E	ECH	OPH	2007
AMPHSQU	<i>Amphipholis squamata</i>	E	ECH	OPH	2012
OPHIALB	<i>Ophiura albida</i>	E	ECH	OPH	2007
OPHILON	<i>Ophioderma longicauda</i>	E	ECH	OPH	2007
OPHIQUI	<i>Ophiothrix quinquemaculata</i>	E	ECH	OPH	2018
OPHISET	<i>Ophiacantha setosa</i>	E	ECH	OPH	2013
ABRAPRI	<i>Abra prismatica</i>	E	MOL	BIV	2007
ABRRALB	<i>Abra alba</i>	E	MOL	BIV	2007
ACANACU	<i>Acanthocardia aculeata</i>	E	MOL	BIV	2007
ACANDES	<i>Acanthocardia deshayesii</i>	E	MOL	BIV	2015
ACANECH	<i>Acanthocardia echinata</i>	E	MOL	BIV	2007
ACANPAU	<i>Acanthocardia paucicostata</i>	E	MOL	BIV	2007
ACANTUB	<i>Acanthocardia tuberculata</i>	E	MOL	BIV	2007
ANADDEM	<i>Anadara transversa</i>	E	MOL	BIV	2007
ANADINA	<i>Anadara inaequalis</i>	E	MOL	BIV	2007
ANADKAG	<i>Anadara kagoshimensis</i>	E	MOL	BIV	2018
ANGLALB	<i>Peronaea planata</i>	E	MOL	BIV	2012
ANODFRA	<i>Loripinus fragilis</i>	E	MOL	BIV	2015
ANOMEPH	<i>Anomia ephippium</i>	E	MOL	BIV	2007
ARCANOA	<i>Arca noae</i>	E	MOL	BIV	2007
ATRIPEC	<i>Atrina pectinata</i>	E	MOL	BIV	2007
BARBBAR	<i>Barbatia barbata</i>	E	MOL	BIV	2016
CHLAFLE	<i>Flexopecten flexuosus</i>	E	MOL	BIV	2007
CHLAVAR	<i>Mimachlamys varia</i>	E	MOL	BIV	2007
CLAUBRO	<i>Clausinella fasciata</i>	E	MOL	BIV	2012
CORBGIB	<i>Corbula gibba</i>	E	MOL	BIV	2007
CRASGIG	<i>Magallana gigas</i>	E	MOL	BIV	2007
CUSPCUS	<i>Cuspidaria cuspidata</i>	E	MOL	BIV	2007

SoleMon Code	Name	Faunistic category	Taxon 1	Taxon 2	Year of introduction
DOSILUP	<i>Dosinia lupinus</i>	E	MOL	BIV	2007
ECHICOR	<i>Echinocardium cordatum</i>	E	MOL	BIV	2007
GARIFER	<i>Gari fervensis</i>	E	MOL	BIV	2018
GLOUHUM	<i>Glossus humanus</i>	E	MOL	BIV	2007
GLYCINS	<i>Glycymeris nummaria</i>	E	MOL	BIV	2015
GLYCPIL	<i>Glycymeris pilosa</i>	E	MOL	BIV	2011
HIATARC	<i>Hiatella arctica</i>	E	MOL	BIV	2007
HIATRUG	<i>Hiatella rugosa</i>	E	MOL	BIV	2012
LAEVCAR	<i>Laevicardium oblongum</i>	E	MOL	BIV	2007
LIMAHIA	<i>Limaria hians</i>	E	MOL	BIV	2010
LIMATUB	<i>Limaria tuberculata</i>	E	MOL	BIV	2007
LUTRSPP	<i>Lutraria spp.</i>	E	MOL	BIV	2007
MACTSTU	<i>Maetra stultorum</i>	E	MOL	BIV	2007
MODISUB	<i>Musculus subpictus</i>	E	MOL	BIV	2007
MUSCSEN	<i>Arcuatula senhousia</i>	E	MOL	BIV	2007
NEOPCOC	<i>Neopycnodonte cochlear</i>	E	MOL	BIV	2007
NUCULSP	<i>Nuculana sp.</i>	E	MOL	BIV	2007
NUCUNIT	<i>Nucula nitidosa</i>	E	MOL	BIV	2007
NUCUNUC	<i>Nucula nucleus</i>	E	MOL	BIV	2007
NUCUPEL	<i>Lembulus pella</i>	E	MOL	BIV	2007
NUCUSUL	<i>Nucula sulcata</i>	E	MOL	BIV	2007
OSTRPAR	<i>Ostrea stentina</i>	E	MOL	BIV	2018
PAPHAUR	<i>Polititapes aureus</i>	E	MOL	BIV	2007
PAPHSPP	<i>Paphia spp.</i>	E	MOL	BIV	2007
PARVICASP	<i>Parvicardium sp.</i>	E	MOL	BIV	2016
PHARLEG	<i>Pharus legumen</i>	E	MOL	BIV	2012
PHAXADR	<i>Phaxas adriaticus</i>	E	MOL	BIV	2018
PITARUD	<i>Pitar rudis</i>	E	MOL	BIV	2007
PODOPAT	<i>Pododesmus patelliformis</i>	E	MOL	BIV	2007
PSEUCLA	<i>Pseudamussium clavatum</i>	E	MOL	BIV	2014
PTERHIR	<i>Pteria hirundo</i>	E	MOL	BIV	2007
SOLESTR	<i>Solecortus strigilatus</i>	E	MOL	BIV	2007
SPISSUB	<i>Spisula subtruncata</i>	E	MOL	BIV	2005
STRILAC	<i>Striarca lactea</i>	E	MOL	BIV	2012
TALOMUL	<i>Talochlamys multistriata</i>	E	MOL	BIV	2015
TELLALB	<i>Peronidia albicans</i>	E	MOL	BIV	2018
TELLDIS	<i>Moerella distorta</i>	E	MOL	BIV	2007
TELLINC	<i>Bosemprella incarnata</i>	E	MOL	BIV	2015
TELLNIT	<i>Peronidia albicans</i>	E	MOL	BIV	2007
TELLSER	<i>Serratina serrata</i>	E	MOL	BIV	2007
THRAPUB	<i>Thracia pubescens</i>	E	MOL	BIV	2013
TIMOOVA	<i>Timoclea ovata</i>	E	MOL	BIV	2007
TIMOSPP	<i>Timoclea spp.</i>	E	MOL	BIV	2017
ACTETOR	<i>Acteon tornatilis</i>	E	MOL	GAS	2007
ARMITIG	<i>Armina tigrina</i>	E	MOL	GAS	2007
CALICHI	<i>Calyptrea chinensis</i>	E	MOL	GAS	2007
CALLVIR	<i>Calliostoma virescens</i>	E	MOL	GAS	2007
CALLZIZ	<i>Calliostoma sp.</i>	E	MOL	GAS	2012
CANIGRA	<i>Calliostoma granulatum</i>	E	MOL	GAS	2007
CERIVUL	<i>Cerithium vulgatum</i>	E	MOL	GAS	2007
DENDLIM	<i>Dendrodoris limbata</i>	E	MOL	GAS	2013
DIODGRE	<i>Diodora graeca</i>	E	MOL	GAS	2007
DIODITA	<i>Diodora italica</i>	E	MOL	GAS	2007
EPITCLA	<i>Epitonium clathrus</i>	E	MOL	GAS	2007

SoleMon Code	Name	Faunistic category	Taxon 1	Taxon 2	Year of introduction
EUSPGUI	<i>Euspira guilleminii</i>	E	MOL	GAS	2016
FUSIROS	<i>Gracilipurpura rostrata</i>	E	MOL	GAS	2007
GASTDUB	<i>Rocellaria dubia</i>	E	MOL	GAS	2007
GIBBMAG	<i>Gibbula magus</i>	E	MOL	GAS	2007
HADRCRA	<i>Hadriana craticulata</i>	E	MOL	GAS	2007
HALIVIR	<i>Haliotis virginea</i>	E	MOL	GAS	2016
NASSINC	<i>Tritia incrassata</i>	E	MOL	GAS	2007
NASSLIM	<i>Tritia lima</i>	E	MOL	GAS	2007
NASSNIT	<i>Tritia nitida</i>	E	MOL	GAS	2007
NASSRET	<i>Tritia reticulata</i>	E	MOL	GAS	2007
NATIHEB	<i>Naticarius hebraeus</i>	E	MOL	GAS	2007
NEVEJOS	<i>Neverita josephina</i>	E	MOL	GAS	2007
OCINEDW	<i>Ocenebra edwardsii</i>	E	MOL	GAS	2007
PELTATR	<i>Peltdoris atromaculata</i>	E	MOL	GAS	2007
PHILAPE	<i>Philine aperta</i>	E	MOL	GAS	2007
PISIDSP	<i>Pisidia sp.</i>	E	MOL	GAS	2007
POLINIT	<i>Euspira nitida</i>	E	MOL	GAS	2013
POLISPP	<i>Polinices spp.</i>	E	MOL	GAS	2017
PSEUADR	<i>Pseudosimnia adriatica</i>	E	MOL	GAS	2012
SCAPNIG	<i>Scaphander lignarius</i>	E	MOL	GAS	2007
TETHFIM	<i>Tethys fimbria</i>	E	MOL	GAS	2005
TONNGAL	<i>Tonna galea</i>	E	MOL	GAS	2008
TRITPYG	<i>Tritia pygmaea</i>	E	MOL	GAS	2019
TROCSP	<i>Trochus spp.</i>	E	MOL	GAS	2012
TURRCOM	<i>Turritella communis</i>	E	MOL	GAS	2005
CHITOSP	<i>Chiton sp.</i>	E	MOL	PLA	2007
DENTINA	<i>Antalis inaequicostata</i>	E	MOL	SCA	2007
SCAPHSP	<i>Scaphopoda sp.</i>	E	MOL	SCA	2018
PLAMSPP	<i>Platelmintes spp.</i>	E	PLA	PLA	2011
AAPTAAP	<i>Aaptos aaptos</i>	E	POR	DEM	2007
ACNTLSP	<i>Echinopora sp.</i>	E	POR	DEM	2011
APLYAER	<i>Aplysina aerophoba</i>	E	POR	DEM	2007
APLYCAV	<i>Aplysina cavernicola</i>	E	POR	DEM	2007
AXINAUR	<i>Axinyssa aurantiaca</i>	E	POR	DEM	2013
AXINCAN	<i>Axinella cannabina</i>	E	POR	DEM	2018
BUBAVER	<i>Bubaris vermiculata</i>	E	POR	DEM	2013
CHONNUC	<i>Chondrilla nucula</i>	E	POR	DEM	2018
CLATCOR	<i>Clathria (Clathria) coralloides</i>	E	POR	DEM	2007
CLIOCEL	<i>Cliona celata</i>	E	POR	DEM	2007
DICTPEL	<i>Dictyonella pelligera</i>	E	POR	DEM	2013
DYSIAVA	<i>Dysidea avara</i>	E	POR	DEM	2017
DYSIPER	<i>Dysidea perfistulata</i>	E	POR	DEM	2013
ECHINSP	<i>Echinoclathria sp.</i>	E	POR	DEM	2015
ECHITRA	<i>Echinoclathria translata</i>	E	POR	DEM	2013
ERYLSPP	<i>Erylus spp.</i>	E	POR	DEM	2019
GEODCYD	<i>Geodia cydonium</i>	E	POR	DEM	2007
HALIARE	<i>Haliclona (Soestella) arenata</i>	E	POR	DEM	2013
HALICIN	<i>Haliclona (Reniera) cinerea</i>	E	POR	DEM	2013
IRCINSP	<i>Ircinia sp.</i>	E	POR	DEM	2007
LISSCAD	<i>Lissodendoryx (Lissodendoryx) caduca</i>	E	POR	DEM	2013
LISSCAV	<i>Lissodendoryx (Anomodoryx) cavernosa</i>	E	POR	DEM	2013
LISSOSP	<i>Lissodendoryx (Ectyodoryx)</i>	E	POR	DEM	2013
MICRSPP	<i>Microcionidae spp.</i>	E	POR	DEM	2013
MYCACON	<i>Mycale (Aegogropila) contarenii</i>	E	POR	DEM	2013

SoleMon Code	Name	Faunistic category	Taxon 1	Taxon 2	Year of introduction
MYCASYR	<i>Mycale (Aegogropila) syrinx</i>	E	POR	DEM	2013
PACHYSP	<i>Pachymatisma sp.</i>	E	POR	DEM	2013
PETRFIC	<i>Petrosia (Petrosia) ficiformis</i>	E	POR	DEM	2018
POLYMAM	<i>Polymastia mamillaris</i>	E	POR	DEM	2007
RASPVIM	<i>Raspailia (Raspailia) viminalis</i>	E	POR	DEM	2007
RHIZPIR	<i>Rhizaxinella pyrifer</i>	E	POR	DEM	2007
SUBECAR	<i>Suberites carnosus</i>	E	POR	DEM	2007
SUBEDOM	<i>Suberites domuncula</i>	E	POR	DEM	2007
SUBESPP	<i>Suberites spp.</i>	E	POR	DEM	2007
TEDAANH	<i>Tedania (Tedania) anhelans</i>	E	POR	DEM	2013
TETHAUR	<i>Tethya aurantium</i>	E	POR	DEM	2007
THETCIT	<i>Tethya citrina</i>	E	POR	DEM	2016
ULOSSP	<i>Ulosa sp.</i>	E	POR	DEM	2013
ASPIMUE	<i>Aspidosiphon (Aspidosiphon) muelleri muelleri</i>	E	SIP	SIP	2007
SIPUNUD	<i>Sipunculus (Sipunculus) nudus</i>	E	SIP	SIP	2007
APLICON	<i>Aplidium conicum</i>	E	TUN	ASC	2007
ASCIASP	<i>Ascidia aspersa</i>	E	TUN	ASC	2007
ASCIMEN	<i>Ascidia mentula</i>	E	TUN	ASC	2007
ASCIVIR	<i>Ascidia virginea</i>	E	TUN	ASC	2007
BOTRLEA	<i>Botrylloides leachii</i>	E	TUN	ASC	2007
BOTRSCH	<i>Botryllus schlosseri</i>	E	TUN	ASC	2007
CIONSP	<i>Ciona spp.</i>	E	TUN	ASC	2018
DIDEMAC	<i>Didemnum maculosum</i>	E	TUN	ASC	2007
DIDEMSP	<i>Didemnum sp.</i>	E	TUN	ASC	2007
HALOPAP	<i>Halocynthia papillosa</i>	E	TUN	ASC	2007
MICRSUL	<i>Microcosmus vulgaris</i>	E	TUN	ASC	2007
MOLGUSP	<i>Molgula sp.</i>	E	TUN	ASC	2007
PHALMAM	<i>Phallusia mammillata</i>	E	TUN	ASC	2007
POLYADR	<i>Polycitor adriaticus</i>	E	TUN	ASC	2014
PYURADU	<i>Pyura dura</i>	E	TUN	ASC	2013
PYURSP	<i>Pyura sp.</i>	E	TUN	ASC	2007
STYECAN	<i>Styela canopus</i>	E	TUN	ASC	2007
	Reptiles				
CARECAR	<i>Caretta caretta</i>	R	VER	REP	2010
	Plantae				
CYMONOD	<i>Cymodocea nodosa</i>	V	TRA	MAG	2016
POSIOCE	<i>Posidonia oceanica</i>	V	TRA	MAG	2013

List of litter subcategories and codes

SOLEMON CODE	DESCRIPTION	FAU. CAT.	YEAR
LITA1	Bottles	G	2013
LITA10	Strapping bands	G	2013
LITA11	Crates and containers	G	2013
LITA12	Mussel farm ropes	G	2013
LITA13	Other plastic	G	2013
LITA14	Food containers/wrappers	G	2017
LITA15	Other fishing-related (pots, floats, etc.)	G	2017
LITA2	Sheets, industrial packaging, plastic sheeting	G	2013
LITA3	Bags	G	2013
LITA4	Caps/lids	G	2013
LITA5	Fishing lines (monofilament)	G	2013
LITA6	Fishing lines (entangled)	G	2013
LITA7	Synthetic rope	G	2013
LITA8	Fishing nets	G	2013
LITA9	Cable ties	G	2013
LITB1	Diapers	G	2013
LITB2	Cotton buds	G	2013
LITB3	Cigarette butts	G	2013
LITB4	Condoms	G	2013
LITB5	Syringes	G	2013
LITB6	Sanitary towels/tampons	G	2013
LITB7	Other sanitary waste	G	2013
LITC1	Cans (food)	G	2013
LITC10	Large metal objects	G	2017
LITC2	Cans (beverages)	G	2013
LITC3	Fishing-related (weights, hooks, sinkers, lures)	G	2013
LITC4	Drums	G	2013
LITC5	Appliances	G	2013
LITC6	Car parts	G	2013
LITC7	Cables	G	2013
LITC8	Other metals	G	2013
LITC9	Middle-sized containers (of paint, oil, chemicals)	G	2017
LITD1	Boots	G	2013
LITD2	Balloons and balloon sticks	G	2013
LITD3	Bobbins (fishing)	G	2013
LITD4	Tyres	G	2013
LITD5	Gloves	G	2013
LITD6	Other rubber	G	2013
LITE1	Jars	G	2013
LITE2	Bottles	G	2013
LITE3	Fragments	G	2013

LITE4	Other glass/ceramic	G	2013
LITF1	Wood (processed)	G	2013
LITF2	Rope	G	2013
LITF3	Paper/cardboard	G	2013
LITF4	Pallets	G	2013
LITF5	Other natural products	G	2013
LITG1	Clothing/rags	G	2013
LITG2	Shoes	G	2013
LITG3	Other miscellaneous	G	2013
LITG4	Carpets & Furnishings	G	2017
LITG5	Other textiles	G	2017

ANNEX IV. Standard length measurement for crustaceans, cephalopods and fish.

Crustaceans

Lct: cephalothoracic length

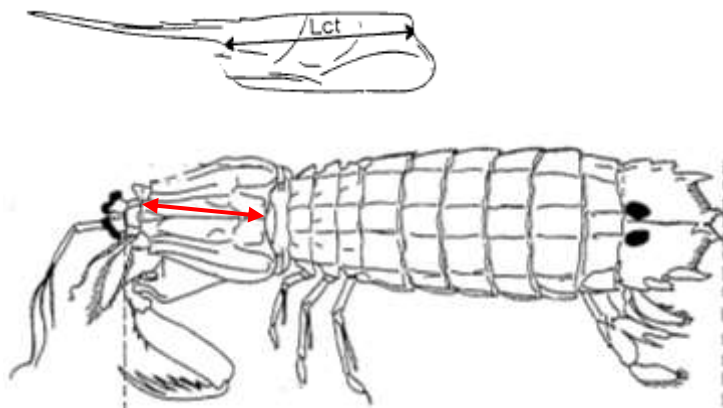

Cephalopods

L: mantle length

Cephalopods decapoda
LM: mantle length

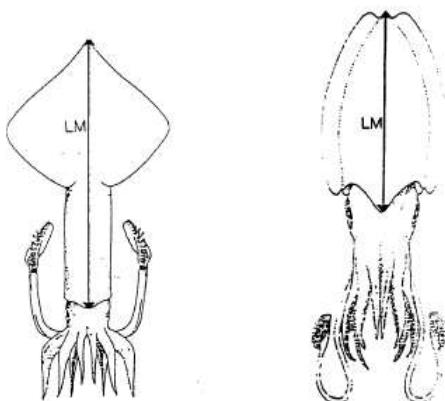

Bivalves

SL: shell length

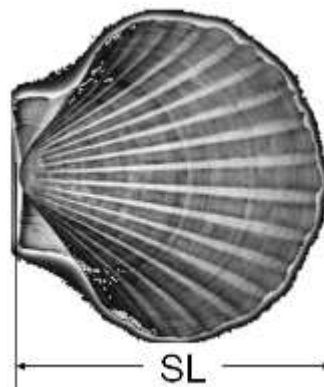

Fish

TL: total length

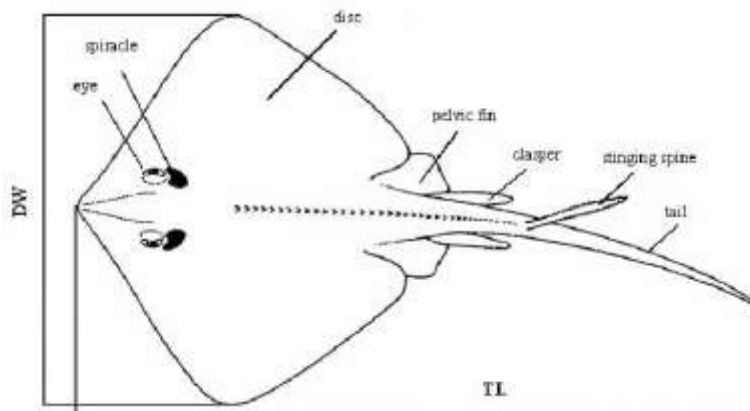

ANNEX V. CODES OF SEXUAL MATURITY FOR FISHES, CRUSTACEANS AND CEPHALOPODS.

V. A COMMON SOLE

Reference pictures of female sole

Stage 1: Primary: Translucent => line test

Secondary: Pale colour, gonad less than $\frac{1}{2}$ of body length, blood vessels threadlike.



Stage 2: Blood vessels taut, tissue healthy and firm compared with stage 5. Egg scan: from grains through to non-hydrated fully developed eggs.



Stages 3-4: Hyaline/hydrated eggs distinguishable. Stage 4 greater amount of eggs.



Stage 5: Blood vessels no longer taut, tissue no longer healthy, gonads already shorter than in stage 4 (Images: ICES, 2012).

Reference pictures for male sole



Stage 1: Primary: semi-skimmed milk colour, kidney shape.



Stage 2: Primary: 3D and more filled out. Secondary: cream colour, from small to maximum size.

Stage 3: Primary: large and full gonads; milt running when squeezed or cut. Secondary: coffee with cream colour. Sperm duct well developed, wide, large and round (no picture available).



Stage 4: Primary: flabby, thinly elongated (lobbed). Secondary: opaque red.

Stage 5: distinguishable?
(no picture available)

V. B Bony Fishes **be careful, these stages are easily confused*

SEX	GONAD ASPECT	MATURATION STATE	STAGE	MEDITS	
I	Sex not distinguishable to naked eye. Gonads very small and translucent, almost transparent. Sex undetermined.	UNDETERMINED	0	0	
F	Small pinkish and translucent ovary shorter than 1/3 of the body cavity. Eggs not visible to naked eye.	IMMATURE/VIRGIN	1	1	
M	Thin and whitish testis shorter than 1/3 of the body cavity.				
F	Small pinkish/reddish ovary shorter than ½ of the body cavity. Eggs not visible to naked eye.	VIRGIN-DEVELOPING*	2a	2	
M	Thin whitish testis shorter than 1/2 of the body cavity.				
F	Pinkish-reddish/ reddish-orange and translucent ovary length about ½ of the body cavity. Blood vessels visible. Eggs not visible to naked eye.	RECOVERING*	2b		
M	Whitish/pinkish testis, more or less symmetrical, length about ½ of the body cavity.				
F	Ovary pinkish-yellow in colour with granular appearance, length about 2/3 of the body cavity. Eggs visible to naked eye through the ovarian tunica, which is not yet translucent. Under light pressure eggs are not expelled	MATURING	2c		
M	Whitish to creamy testis long about 2/3 of the body cavity. Under light pressure sperm is not expelled				
F	Ovary orange-pink in colour, with conspicuous superficial blood vessels, length from 2/3 to full length of the body cavity. Large transparent, ripe eggs clearly visible and may be expelled under light pressure. In more advanced conditions, eggs escape freely.	MATURE/SPAWNER	3		
M	Whitish-creamy soft testis, length from 2/3 to full length of the body cavity. Under light pressure, sperm may be expelled. In more advanced conditions, sperm escapes freely.				
F	Reddish ovary shrunk to about 1/2 length of the body cavity. Flaccid ovary walls; ovary may contain remnants of disintegrating opaque and/or translucent eggs.	SPENT	4a		4
M	Bloodshot and flabby testis shrunk to about 1/2 length of the body cavity.				
F	Pinkish and translucent ovary, length about 1/3 of the body cavity. Eggs not visible to naked eye.	RESTING*	4b		
M	Whitish/pinkish testis, more or less symmetrical, length about 1/3 of the body cavity.				

V. C Oviparous elasmobranchs **be careful, these stages are easily confused*

SEX	GONAD ASPECT	MATURATION STATE	STAGE	MEDITS
N	Sex not distinguished to naked eye.	UNDETERMINED	0	0
F	Ovary barely discernible with small isodiametric eggs. Distal portion of oviducts thick-walled and whitish. Nidamental glands barely evident.	IMMATURE/VIRGIN	1	1
M	Claspers small and flaccid and do not reach the posterior edge of the pelvic fins. Sperm ducts not differentiated. Testis small and narrow.			
F	Whitish and/or few yellow maturing eggs visible in the ovary. Distal part of oviducts (uterus) well developed but empty. Nidamental glands small.	MATURING	2*	2
M	Claspers larger, but skeleton still flexible. They extend to the posterior edge of the pelvic fins. Sperm ducts well developed may begin to meander.			
F	Ovaries contain yellow eggs (large yolk eggs). Nidamental glands enlarged and oviducts distended.	MATURE	3a	3
M	Claspers extend well beyond the posterior edge of the pelvic fin, their internal structure generally hard and ossified. Testis greatly enlarged. Sperm ducts meandering over almost their entire length.			
F	Ovary walls transparent. Oocytes of different sizes, white or yellow. Nidamental glands large. Egg-cases more or less formed in the oviducts (extruding stage).	MATURE/EXTRUDING-ACTIVE	3b	3
M	Clasper longer than tips of posterior pelvic fin lobes, skeleton hardened, with axial cartilages hardened and pointed. Sperm ducts large. Sperm flowing on pressure from cloaca (active stage).			
F	Ovary walls transparent. Oocytes of different sizes, white or yellow. Oviducts much enlarged, collapsed and empty. Nidamental gland diameter decreasing.	RESTING	4a	4
M	Clasper longer than tips of posterior pelvic fin lobes, skeleton hardened with axial cartilages still hardened. Sperm ducts empty and flaccid.			
F	Ovaries full of small follicles similar to stage 2, enlarged oviductal glands and uterus	REGENERATING	4b*	

V. D Crustaceans

SEX	GONAD ASPECT	COLOURING OF FRESH OVARY	MATURATION STATE	STAGE	MEDITS
F	Ovary barely visible. After dissection of tegument, ovary is small and lobes are flaccid, stringy and poorly developed.	Whitish or translucent	Immature virgin*	1	1 FEMALE
M	Petasma not clearly visible; no spermatid masses (emispermaphores) in seminal ampullae on the side of the fifth pair of pereopods.				
F	Ovary is developing. Cephalic and lateral lobes small but discernible to naked eye. The abdominal extensions are thin and slightly visible.	A. foliacea: flesh-coloured; A. antennatus: ivory-coloured with orange pink-violet dotting; N. norvegicus: cream-coloured; P. longirostris: cream orange-coloured.	Developing virgin*	2a	2 FEMALE
M	The petasma is visible and nearly or completely joined, but there are no spermatid masses in the seminal ampullae.				
F	The ovary is starting a new reproductive cycle. The cephalic and lateral lobes are small but discernible to the naked eye. The abdominal extensions are thin and barely visible.	A. foliacea: flesh coloured; A. antennatus: ivory coloured with orange pink-violet dotting; N. norvegicus: cream coloured; P. longirostris: cream orange-coloured.	Recovering*	2b	
M	The petasma appears completely joined but there are no spermatid masses in the seminal ampullae.				
F	The ovary is developed and occupies the dorsal portion almost entirely. The cephalic and lateral lobes are highly developed and have a turgid consistence.	A. foliacea: light and dark grey; A. antennatus: lilla; N. norvegicus: light green; P. longirostris: light green or grey green.	Maturing or almost mature	2c	
M	-				
F	The turgid ovary extends to the whole dorsal portion, covering the organs below. The lobes and extensions are well developed; in particular, the abdominal extensions are highly visible. The oocytes are well developed.	A. foliacea: black; A. antennatus: violet; N. norvegicus: dark green; P. longirostris: bright green or olive green colour.	Mature	2d	
M	The petasma is perfectly visible and completely joined. There is a spermatid mass in the seminal ampullae.				
F	It is a resting ovary.	Uncoloured	Resting adult*	2e	
F (N. norvegicus)	Eggs are present in pleopods.		Berried	3	3 N. norvegicus FEMALE

Maturity stages of *S. mantis* females, ovaries (dorsal cuticle removed):

1 - immature;



2 - early maturation;



3 - advanced maturation;



4 - ripe;



5 - spent.



Maturity stages of *S. mantis* females, cement glands:

1 – immature;



2 - early maturation;



3 -advanced maturation;
(note the yellow ovary already
visible through telson cuticle);



4 – ripe;



5 –spent;
(note the white cement gland and no
evidence of yellow ovary in the telson).



V. E Cephalopods

SEX	GONAD ASPECT	EGG SIZE (mm)	SPERMATOPHORE DEVELOPMENT	MATURATION STATE	STAGE	MEDICALS
I	Sex not discernible to naked eye: undetermined.	Total lack of eggs	Total lack of spermatophores	Undetermined	0	0
F	Nidamental glands (NG)/oviductal glands (OG) small and translucent Ovary semi-transparent and stringy, lacks a granular structure. Oviduct meander not visible.	L. vulgaris and I. coindetii: no eggs; S. officinalis: $\varnothing < 2$ mm; E. moschata: $\varnothing < 4$ mm; E. cirrhosa: $\varnothing < 2$ mm; O. vulgaris: $\varnothing < 1$ mm	Total lack of spermatophores	Immature virgin	1	1
M	Testis small. Spermatophoric complex (SC) semi-transparent, and vas deferens not visible. Penis appears as a small prominence of SC.					
F	NG/OG enlarged. NG cover some internal organs. Whitish ovary has a clearly visible granular structure which does not reach the posterior half of the mantle cavity. Oviduct meander clearly visible.	Very small eggs	Lack of spermatophores	Developing	2a	2
M	The structure of the enlarged testis is not clearly visible. The vas deferens is whitish or white, and the spermatophoric organ has a white streak.					
F	The large NG covers the viscera below. Ovary occupies the entire posterior cavity of mantle cavity and contains tightly packed reticulated oocytes of all sizes and probably a few ripe ova in the proximal parts. Oviducts fully developed but empty.	L. vulgaris and I. coindetii: maturing eggs are visible to the naked eye; S. officinalis: 2.1 mm $< \varnothing < 4$ mm; E. moschata: 4 mm $< \varnothing < 11$ mm; E. cirrhosa: 2 mm $< \varnothing < 5$ mm; O. vulgaris: 1 mm $< \varnothing < 2$ mm	L. vulgaris, I. coindetii and S. officinalis: there are a few immature spermatophores in Needham's sac; E. moschata, E. cirrhosa and O. vulgaris: there are a few spermatophores,	Maturing	2b	
M	Vas deferens white, meandering and enlarged. Needham's sac (SS) has structureless whitish particles inside. Normally, the SS is without functional spermatophores but at times some immature/abortive ones can occur. The testis is tight and crispy, with a visible structure.					

			which are slightly developed and not functional.			
F	The NG as large. The ovary contains a higher percentage of large reticulated eggs and some ripe ova with a smooth surface. In Teuthoidea, the ova in the oviducts are ripe.	L. vulgaris and I. coindetii: amber-coloured and isodiametric eggs in oviducts and in part of the ovary (Ø=2 mm in Loligo and Ø=1 mm in Illex) S. officinalis: medium eggs (4.1 mm<Ø<6 mm) and large eggs 6.1 mm<Ø<8 mm; E. moschata: Ø 11 mm; E. cirrhosa: Ø>5 mm; O. vulgaris: Ø>2 mm	Well developed spermatophores	Mature	3a	3
M	The testis is as above. The spermatophores are packed in the SS.					
F	NG/OG are large but soft and running. The ovary is shrunken and flaccid with only immature oocytes attached to the central tissue and a few loose, large ova in the coelom. In Teuthoidea, the oviduct may contain some mature ova but is no longer packed.	A few large ova	Disintegrating spermatophores	Spent	3b	
M	Spermatophores are disintegrating in the SS and the penis.					